

Energy Audit Report

of

Bharati Vidyapeeth's

College of Fine Arts

Bharati Vidyapeeth Campus, Pune-Satara Road,
Dhankawadi, Pune – 411043



Auditing Agency –Prathamesh Energy Solution, A-302, Shiv Unnati
Residency, Kalepadal, Hadapsar Pune- 411 028

Prathamesh Energy Solution

A-302, Shiv Unnati residency, Kalepadal, Hadapsar, Pune-411028

Ref: PES/BVCOFA/2023-24/22

Date: 16/10/2023

To,

The Principal

Bharati Vidyapeeth's

College of Fine Arts

Pune-Satara Road, Dhankawadi, Pune – 411043

Sub: Submission of Report on Energy Audit of College Campus

Respected Sir,

Please find enclosed herewith the report

Thanking you

Yours faithfully

For Prathamesh Energy Solution

Authorized Signatory

Prathamesh Energy Solution

A-302, Shiv Unnati Residency, Kalepadal, Hadapsar, Pune 411028

Ref: EC/BVCoFA/23-24/21

CERTIFICATE

This is to certify that we have conducted Energy Audit at **Bharati Vidyapeeth's College of Fine Arts, Pune-Satara Road, Dhankawadi, Pune**, in the Academic year 2023-24

.The College has adopted following Energy Efficient **and best** practices:

- Usage of Energy Efficient LED Fittings
- Maximum usage of Day Lighting
- Green Campus
- Rain water Harvesting system

We appreciate the support of Management, involvement of faculty members and students in the process of making the Campus Energy Efficient.

For,

Prathamesh Energy Solution,

Certificate of Registration

This is to Certify that
Quality Management System of

PRATHAMESH ENERGY SOLUTION

A-302, SHIV UNNATI RESIDENCY, KALEPADAL, HADAPSAR, PUNE-411028,
MAHARASHTRA, INDIA.

has been assessed and found to conform to the requirements of
ISO 9001:2015
for the following scope :

CONSULTANCY SERVICES FOR ENERGY AUDIT, GREEN AUDIT AND ENVIRONMENTAL
AUDIT IN EDUCATIONAL INSTITUTIONS AND OTHER ORGANIZATIONS & SUBMISSION OF
AUDIT CERTIFICATE AND REPORT.

Certificate No	: 23EQMD10	Issuance Date	: 19/06/2023
Initial Registration Date	: 19/06/2023	Date of Expiry	: 18/06/2026
Date of Expiry	: 18/06/2026	1st Surve. Due	: 19/05/2024
1st Surve. Due	: 19/05/2024	2nd Surve. Due	: 19/05/2025



Demu..
Director

Magnitude Management Services Pvt. Ltd.

Third Floor, A-60, Sector-2, Noida, Gautam Budh Nagar, U.P.-201301, India

e-mail: info@mmscertification.com, website: www.mmscertification.com

* Subject to Successful Surveillance Audit and case surveillance audit is not allowed to be conducted, this certificate shall be suspended/withdrawal.

Certificate Verification: Please Re-check the validity of certificate at <http://www.mmscertification.com/activeclients.aspx> or www.mmscertification.com at Active Clients.

Certificate is the property of Magnitude Management Services Pvt. Ltd. and shall be returned immediately when demanded.

INDEX

Sr. No	Particulars	Page No
I	Acknowledgement	6
II	Executive Summary	7
III	Abbreviations	10
1	Introduction	11
2	Study of Connected Load	12
3	Historical Data Analysis- Electrical Energy	13
4	Carbon foot printing	17
5	Electrical Measurements	20
6	Scope of renewable energy and efficient facility at college campus	35
8	Suggestions and Recommendations	38

ACKNOWLEDGEMENT

We at Prathamesh Energy Solution, Pune, express our sincere gratitude to the management and Principal of Bharati Vidyapeeth's College of Fine Art, Dhankawadi, Pune for awarding us the assignment of Energy Audit of their College campus located at Pune-Satara Road, Dhankawadi, Pune.

We are very much thankful to

- Dr. Anupama Patil, Principal, BVCoFA, Dhankawadi, Pune
- Mr. Rupesh Pawar, Vice- Principal (Administration), BVCoFA, Dhankawadi, Pune
- Mrs. Mugdha Kale, Vice-Principal (Academics), BVCoFA, Dhankawadi, Pune
- Mr. Sagar Pansare, Coordinator & Assistant Professor, BVCoFA, Dhankawadi, Pune
- Mr. Sudhir Pawar, Coordinator & Assistant Professor, BVCoFA, Dhankawadi, Pune

for giving us opportunity to conduct detailed energy audit of the institute and provide all the required data and information promptly for the smooth conduction of detailed energy and green audit.

We are also thankful to various Heads of Departments, IQAC Coordinator & other Staff members for helping us during the survey and field visit.

We are also thankful to all the technical staff and office staff for helping during the field visit and measurements at the college campus.

EXECUTIVE SUMMARY

After the Field measurements & analysis, we present herewith important observations made and various measures to reduce the Energy Consumption & mitigate the CO₂ emissions

1. Bharati Vidyapeeth's College of Fine Arts, Dhankawadi, Pune, consumes electrical Energy in majority used for various gadgets & office operations.

2. The various projects already implemented by the College are

- Installed APFC of 100kVAR at Main electrical distribution to maintain Power factor.
- Usage of natural day lights and natural air circulation
- Usage of Natural Day light in corridors specifically
- Usage of LED lighting for Admin & outdoor lighting
- Fire extinguishers are installed and maintained for fire safety in the college campus.

3. Important Parameters: Electrical Energy:

Electricity is used for different purposes and at different sections in the college campus. The details of electricity distribution as mentioned below.

Sr. No.	Consumer No.	Electrical Meter No.	Location/Purpose	Payee
1	170019005146	055-XD448280	College building/building operation	Principal, Bharati Vidyapeeth

The important parameters of electrical consumption as per Consumer no. in the campus are mentioned as below.

Sr. No	Consumer No.	Parameter	Max	Min	Average
1	170019005146	Units consumed, kVAh	16232	4031	7436.2
		Electricity Bill amount	370923	197052	246967.7
		Total average units consumed per month, kVAh			7436.2

4. Important Parameters: CO₂ Emissions (Average, MT/Annum)

No	Consumer No.	Particulars	Value MT
1	170019005146	CO ₂ - Emissions- Electricity Usage	71.39
		Total	71.39

On the basis of average electricity consumption CO₂ emission is 71.39MT /annum. In addition to this LPG is being consumed for canteen for food preparation. Nearly LPG consumption annually is 12 commercial cylinders i.e. 228 kg/annum. On the basis of average LPG usage CO₂ emission is 0.68MT/annum.

5. Benchmark: In terms of Electrical Energy & CO₂ emissions:

We now present two important benchmarks in respect of Electrical Energy consumption & CO₂ emissions as under.

No	Particulars	Value	Unit
1	Electrical Energy consumed	0.61	kWh/sq. ft.
3	CO ₂ - Emissions	1.55	Kg per annum /sq. ft.

6. Recommendations:

We present herewith various proposals to reduce the Electrical Energy demand and reduce the CO₂ emissions

S. No.	Recommendation	Annual saving potential in kWh /Kg of LPG	Annual Saving Potential in MT of CO ₂	Annual monetary gain, Rs.
1	Installation of 50kW Solar PV roof top on college building	84000 kWh	67.2	840000
2	Solar street lights	262.8 kWh	0.21	2628
3	Solar powered light for hoarding	-	-	-
4	Solar charging stations	-	-	-
	Total	84262.8	67.41	842628

Notes & assumptions:

- 1 Unit of Electrical Energy releases 0.8 Kg of CO₂ into atmosphere
- 1 Kg of LPG releases 3 Kg of CO₂ into atmosphere
- Daily working hours-10
- Annual working Days-280
- Average Rate of Electrical Energy- Rs 10 per kWh

ABBREVIATIONS

DP	: Double Pole
CFL	: Compact Fluorescent Lamp
EESL	: Energy Efficiency Services Limited
F P	: Feeder Pillar
MSEDCL	: Maharashtra State Electricity Distribution Company Ltd.
MEDA	: Maharashtra Energy Development Agency
MIDC	: Maharashtra Industrial Development Corporation
V	: Voltage
I	: Current
kW	: kilo-Watt
kVA	: Apparent Power
kVA _r	: Reactive Power
P F	: Power Factor
kW _p	: Kilo Watt peak

CHAPTER- ENERGY AUDIT: INTRODUCTION

1.1 Objectives:

1. To study present level of Energy Consumption
2. To Study the present CO₂ emissions
3. To assess the various equipment/facilities from Energy efficiency aspect
4. To measure various Electrical parameters
5. To study Scope for usage of Renewable Energy
6. To study various measures to reduce the Energy Consumption

1.2 Audit Methodology:

1. Study of connected load
2. Study of various Electrical parameters
3. To prepare the Report with various ENCON measures with payback analysis

1.3 Energy Audit Instruments:

1. Portable Power Analyzer
2. Lux meter
3. Anemometer
4. Digital Temperature Indicator
5. CO₂ Meter
6. Water TDS meter

1.4 General Details of Bharati Vidyapeeth's College of Fine Arts, Pune:

No	Head	Particulars
1	Name of Institution	Bharati Vidyapeeth's College of Fine Arts, Pune
2	Address	Pune-Satara Road, Dhankawadi, Pune
3	Year of Establishment	2000
4	Salient Features	Affiliated to Savitribai Phule Pune University
4	Courses offered	BFA Painting and BFA Applied Art
5	No of Students	266
6	Total built up area	45940 Sq. ft.

CHAPTER-II

STUDY OF CONNECTED LOAD

In this chapter, we present the details of various Electrical loads as under

2.1 Study of Fitting wise Connected Load:

Sr. No.	Types of fittings	Load/unit	Quantity	Load in kW
1	Fan	66	148	9.77
2	Tube light	40	315	12.60
3	Bulb	60	05	0.30
4	Desktop	150	73	10.95
5	Printer	200	09	1.80
6	AC	1500	03	4.50
7	Water cooler	1500	01	1.50
8	LED street lights	18	06	0.11
9	Motor	3500	03	10.50
10	LED Display	1200	05	6.00
11	Stand Fan	50	03	0.15
Total				58.18

We present the same in a PIE Chart as under

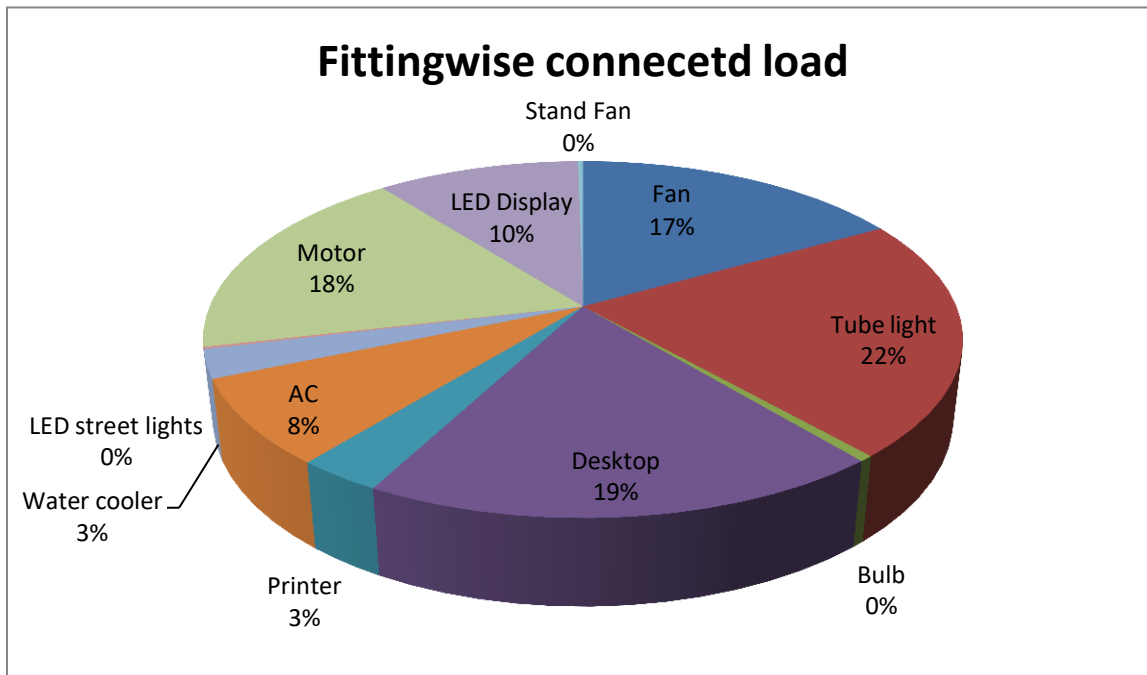

CHAPTER-III

HISTORICAL DATA ANALYSIS: ELECTRICAL ENERGY

In this chapter, we present the analysis of last year Electricity Bills

3.1 Consumer No. 170019005146

This consumer is the major contributors for billing in the Bharati Vidyapeeth campus. BV College of Fine Arts building load is connected to the same meter. Monthly consumption for last few months and bill amount is as follows.

Table No. 1: Electrical Bill Analysis- 2022-23: 170019005146

Sr. No	Month	kVAh	Demand	Amount
1	July-23	16232	266	370923
2	June-23	6303	266	248130
3	May-23	4663	266	230003
4	April-23	6290	266	248891
5	March-23	4583	247	205283
6	Feb-23	4351	247	201292
7	Jan-23	6573	247	230262
8	Dec-22	7286	247	230828
9	Nov-22	4397	247	202461
10	Oct-22	4031	247	197052
11	Sep-22	14731	247	331950
12	Aug-22	9795	247	266537
13	Total	89235		2963612
14	Average	7436.2	253.3	246967.7
15	Max	16232	266	370923
16	Min	4031	247	197052

3.1.1 To study the variation of Monthly Units' Consumption:

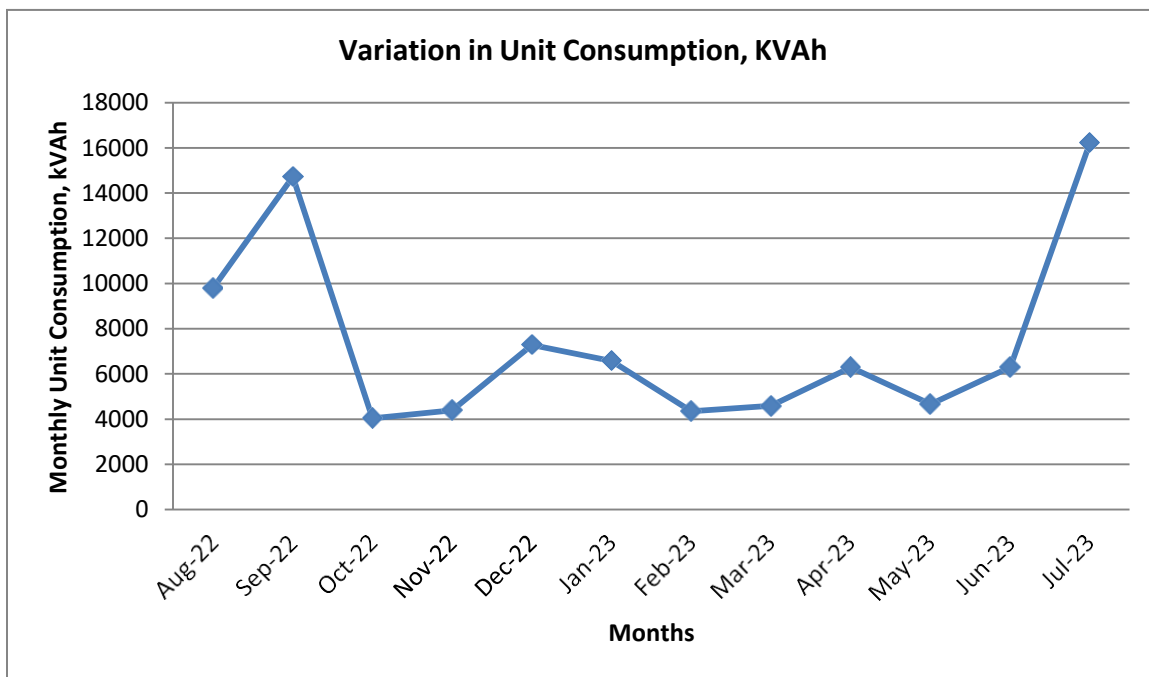

3.1.2 To study the variation of Demand

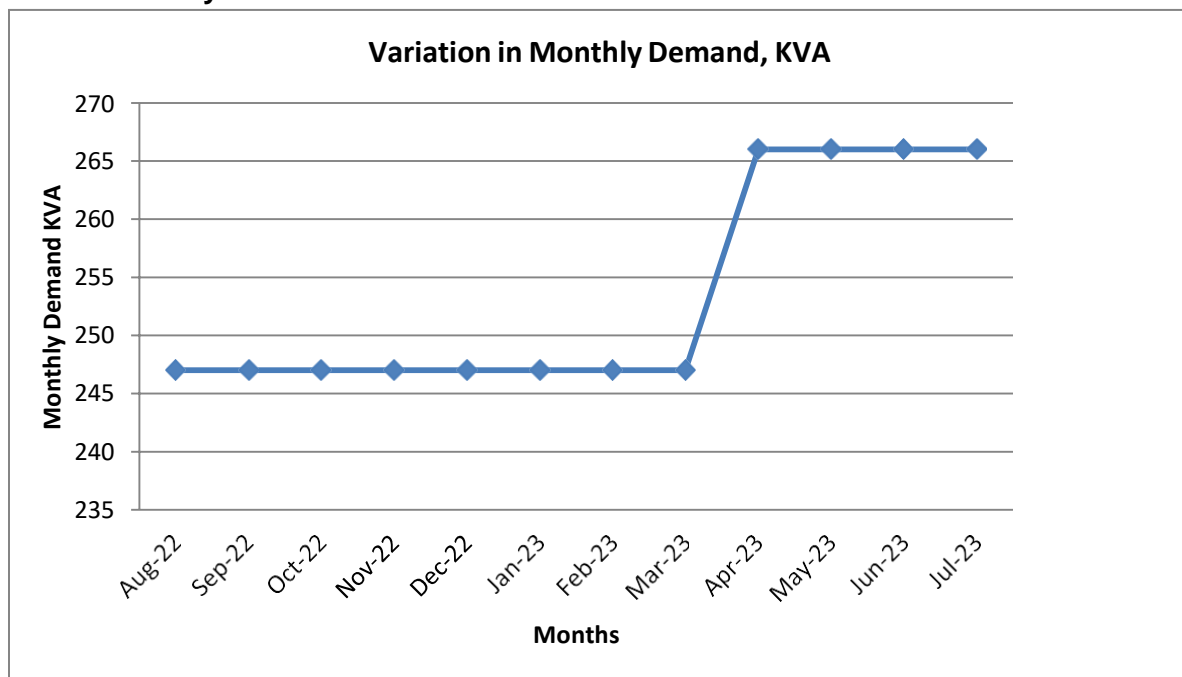

3.1.3 To study the variation of Monthly Electricity Bill:

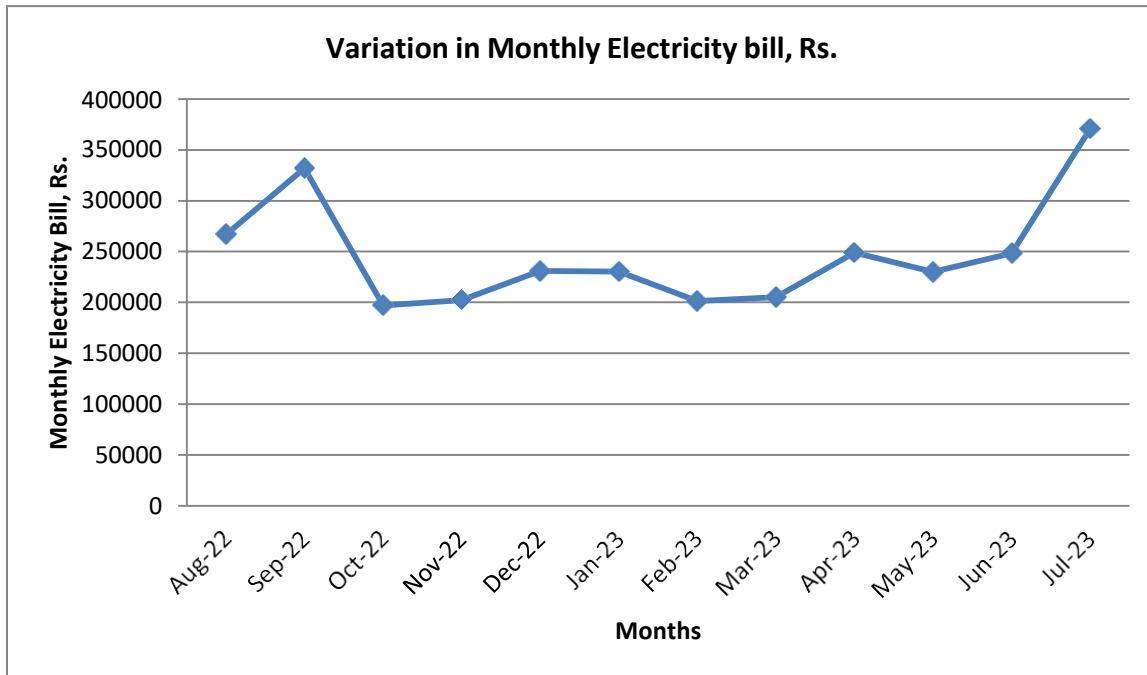

3.2 Summary:

Sr. No.	Consumer No.	Annual Electricity Consumption, kVAh	Annual Bill, Rs
1	170019005146	89235	2963612

3.3 Key Inference drawn:

From the above analysis, we present following important parameters:

Sr. No	Consumer No.	Parameter	Max	Min	Average
1	170019005146	Units consumed, kVAh	16232	4031	7436.2
		Electricity Bill amount	370923	197052	246967.7
		Total average units consumed per month, kVAh			7436.2

3.4 Benchmarking:

Now we compute the Electrical Energy Consumed per square feet of the College Building as under

No	Parameter	Value	Unit
1	Units consumed, kWh	7436.2	kWh
2	College area	45940	Sq. ft.
3	Unit consumed/sq. ft.	0.61	kWh/sq. ft.

CHAPTER-IV

CARBON FOOTPRINTING

A Carbon Foot print is defined as the Total Greenhouse Gas emissions, emitted due to various activities.

In this we compute the emissions of Carbon-Di-Oxide, by usage of the various forms of Energy used by the College for performing its day to day activities. The college uses electrical energy for operating various electrical gadgets.

We herewith furnish the details of electrical Energy consumption consumer number wise as under

4.1 Month wise Consumption of Electrical Energy: 170019005146

Sr. No	Month	kVAh
1	July-23	16232
2	June-23	6303
3	May-23	4663
4	April-23	6290
5	March-23	4583
6	Feb-23	4351
7	Jan-23	6573
8	Dec-22	7286
9	Nov-22	4397
10	Oct-22	4031
11	Sep-22	14731
12	Aug-22	9795
13	Total	89235
14	Average	7436.2
15	Max	16232
16	Min	4031

4.2 Basis for computation of CO₂ Emissions:

The basis of Calculation for CO₂ emissions due to Electrical Energy are as under

- 1 Unit (kWh) of Electrical Energy releases **0.8 Kg of CO₂** into atmosphere

Based on the above Data we compute the CO₂ emissions which are being released in to the atmosphere by the College due to its Day to Day operations.

4.3 Month wise CO2 Emissions: 170019005146

Sr. No	Month	Electrical Energy Consumed, kVAh	CO2 Emissions due to Electricity, MT
1	July-23	16232	12.99
2	June-23	6303	5.04
3	May-23	4663	3.73
4	April-23	6290	5.03
5	March-23	4583	3.67
6	Feb-23	4351	3.48
7	Jan-23	6573	5.26
8	Dec-22	7286	5.83
9	Nov-22	4397	3.52
10	Oct-22	4031	3.22
11	Sep-22	14731	11.78
12	Aug-22	9795	7.84
13	Total	89235	71.39
14	Average	7436.2	5.95
15	Max	16232	12.99
16	Min	4031	3.22

4.4 Representation of Month wise CO₂ emissions:

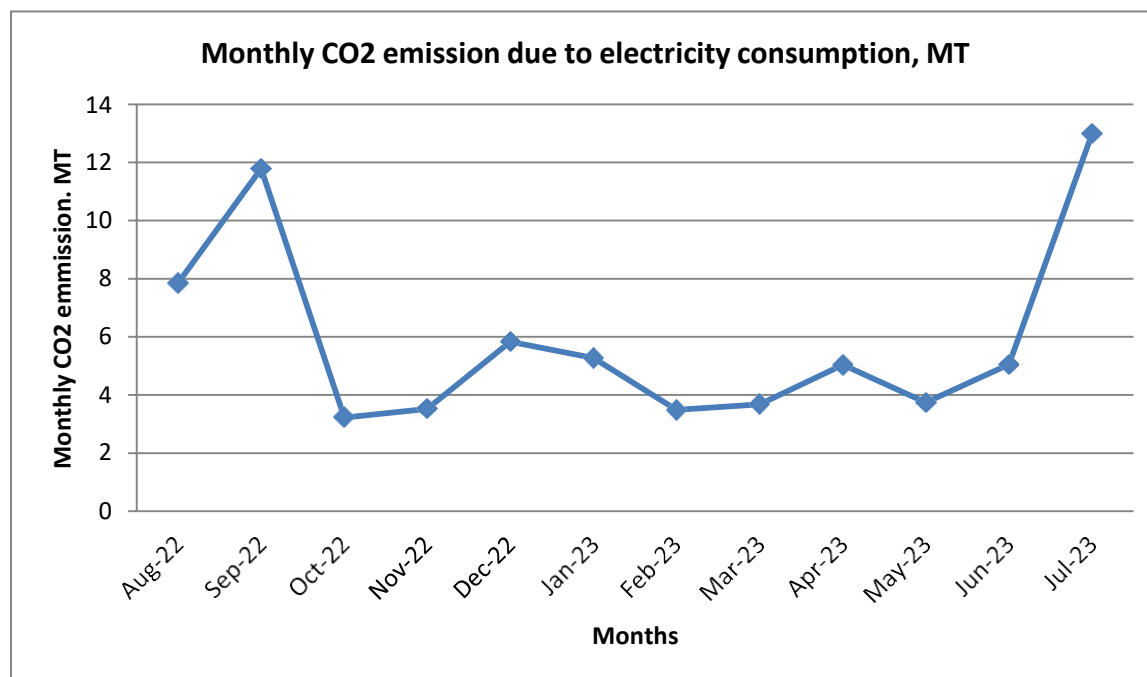

4.5 Benchmarking:

Now we compute the CO₂ emissions per sq. ft. basis as under:

No	Parameter	Value	Unit
1	CO ₂ emissions	71.39	MT/annum
2	College area	45940	Sq. ft.
3	CO₂ emissions/sq. ft.	1.55	Kg of CO₂ per annum/sq. ft.

CHAPTER-V

ELECTRICAL MEASUREMENTS

In this Chapter, we present the details of measurements at the distribution center and main meter room.

5.1 Measurement at Main Incomer feeder:

With the help of power analyzer various electrical parameters like voltage, current, KW and PF are measured. The sample extract of measured data is as follows.

Recording																	
Date:	U12 rms	U23 rms	U31 rms	A1 rms	A2 rms	A3 rms	PT (kW)	PF1	PF2	PF3	PFT	V1 THDf	V2 THDf	V3 THDf	A1 THDf	A2 THDf	A3 THDf
	V	V	V	A	A	A	kW					% f	% f	% f	% f	% f	% f
30-10-2023	410	411.4	413.5	21.07	21.9	16.01	13.66	0.96	0.98	0.99	0.98	2.3	1.7	1.7	17.3	7.2	9
30-10-2023	410	411.9	414.1	20.99	21.9	16.1	13.69	0.96	0.98	0.99	0.98	2.1	1.8	1.6	17.5	6.8	9.4
30-10-2023	411	412.2	414.5	20.96	21.9	16.12	13.7	0.96	0.98	0.99	0.98	2.2	1.8	1.6	17.5	6.7	9.2
30-10-2023	411	412.6	415	20.89	21.9	16.09	13.68	0.97	0.98	0.99	0.98	2.2	1.8	1.7	17.3	6.9	9
30-10-2023	411	412.3	414.6	20.85	21.8	16.07	13.65	0.97	0.98	0.99	0.98	2.2	1.8	1.7	17.2	6.9	9.1
30-10-2023	410	412	414.4	20.88	21.9	16.2	13.68	0.96	0.98	0.99	0.98	2.2	1.7	1.7	17.2	6.9	9
30-10-2023	411	412.2	414.5	20.9	21.9	16.36	13.73	0.96	0.98	0.99	0.98	2	1.5	1.4	17	6.6	9.6
30-10-2023	411	412.1	414.4	20.88	21.9	16.48	13.76	0.96	0.98	0.99	0.98	2	1.5	1.5	17	6.6	9.5
30-10-2023	410	411.8	414.3	20.83	22	16.55	13.76	0.96	0.98	0.99	0.98	2.2	1.8	1.7	17	7.2	10.1
30-10-2023	410	411.7	414.4	20.79	22	17.13	13.9	0.96	0.98	0.99	0.98	2.2	1.8	1.7	16.8	7.2	9.8
30-10-2023	410	411.9	414.3	20.79	22	17.18	13.91	0.96	0.98	0.98	0.97	2.2	1.8	1.7	17.1	7.4	10.3
30-10-2023	410	411.9	414.2	20.78	22	17.09	13.89	0.96	0.98	0.99	0.98	2.3	1.8	1.7	16.9	7.2	10.2
30-10-2023	410	411.5	413.7	20.78	22	17.19	13.89	0.96	0.98	0.98	0.97	2	1.6	1.6	16.8	6.9	10.8
30-10-2023	410	411.4	413.7	20.78	22.1	17.23	13.92	0.96	0.98	0.98	0.97	2	1.5	1.5	16.9	6.9	10.8
30-10-2023	409	411.1	413.6	20.84	22.2	17.21	13.94	0.96	0.98	0.98	0.97	2.1	1.7	1.7	17	7.1	11
30-10-	409	411.2	413	20.82	22.1	17.19	13.91	0.96	0.98	0.98	0.97	2.2	1.7	1.8	17.2	7.3	10.7

2023																	
30-10-2023	410	411.6	414	20.85	22	17.15	13.92	0.96	0.98	0.98	0.98	2.3	1.8	1.7	17.1	7.1	10.4
30-10-2023	411	412	414.7	20.83	22	17.04	13.91	0.97	0.98	0.99	0.98	2.3	1.8	1.7	17	7.2	10.5
30-10-2023	410	412	414.2	20.86	22	17.03	13.9	0.96	0.98	0.99	0.97	2.2	1.7	1.6	17.6	7.3	10.5
30-10-2023	411	412	414.4	20.81	22	17.04	13.88	0.96	0.98	0.99	0.97	2.2	1.7	1.6	17.2	7.1	10.6
30-10-2023	410	411.7	414.1	20.8	22	17.04	13.87	0.96	0.98	0.99	0.97	2.2	1.7	1.7	17.4	7.3	10.6
30-10-2023	410	411.7	413.8	20.82	21.9	17.03	13.84	0.96	0.98	0.99	0.97	2.2	1.7	1.7	17.4	7	10.8
30-10-2023	410	411.9	413.9	20.82	22.1	17.07	13.92	0.96	0.98	0.99	0.98	2.2	1.8	1.8	17.1	7.1	10.4
30-10-2023	410	412	414.1	20.8	22	17.07	13.89	0.97	0.98	0.99	0.98	2.2	1.8	1.8	16.9	7.2	10.3
30-10-2023	411	412.4	414.4	20.78	22	17.04	13.89	0.96	0.98	0.99	0.98	2.3	1.8	1.8	17.1	7.3	9.9
30-10-2023	411	412.3	414.4	20.78	22	16.98	13.88	0.96	0.98	0.99	0.98	2.3	1.8	1.8	17.1	7.2	10.1
30-10-2023	410	412.1	414	20.75	21.9	17.01	13.85	0.96	0.98	0.99	0.98	2.2	1.7	1.8	17	7	10
30-10-2023	411	413.1	415.2	20.74	22.1	17	13.93	0.96	0.98	0.99	0.98	2.2	1.8	1.6	17.4	7.2	10.2
30-10-2023	412	413.5	415.6	20.8	22	16.99	13.93	0.96	0.98	0.99	0.97	2.2	1.7	1.7	17.6	7.3	10.4
30-10-2023	411	412.9	415	20.68	22	16.96	13.87	0.96	0.98	0.99	0.98	2.2	1.7	1.6	17.3	7.2	10.1
30-10-2023	412	413.3	415.3	20.65	22	17	13.89	0.97	0.98	0.99	0.98	2.2	1.7	1.7	16.8	6.9	10
30-10-2023	412	413.2	414.7	20.66	21.9	16.99	13.85	0.97	0.98	0.99	0.98	2.1	1.8	1.7	16.9	7	10.1
30-10-2023	412	413.3	415.1	20.72	22.2	17.04	13.94	0.97	0.98	0.99	0.98	2.2	1.8	1.8	16.9	7.2	10.5
30-10-2023	412	413.2	415.3	20.73	22.1	16.96	13.9	0.97	0.98	0.99	0.98	2.1	1.6	1.5	16.8	7.1	10.1
30-10-2023	412	413.6	415.5	20.76	22.1	17	13.95	0.96	0.98	0.99	0.98	2	1.4	1.5	16.9	7.1	10
30-10-2023	411	413	414.9	20.76	21.9	17.05	13.89	0.96	0.98	0.99	0.97	2	1.5	1.5	17	7.2	10.4
30-10-2023	412	413.1	415.2	20.76	21.9	17.05	13.89	0.96	0.98	0.99	0.97	2.2	1.7	1.7	17.1	7.3	10.6
30-10-2023	412	414	416.6	20.78	22.2	17.02	14.01	0.97	0.98	0.99	0.98	2	1.6	1.7	16.6	7.3	10.4
30-10-2023	412	413.1	415.7	20.79	23.2	16.98	14.16	0.97	0.97	0.99	0.97	2.1	1.6	1.7	16.8	6.7	10.5

30-10-2023	411	412.6	415	20.84	23.4	16.94	14.2	0.96	0.97	0.99	0.97	2.3	1.8	1.8	17.2	6.4	10.5
30-10-2023	411	412.4	415	20.87	23.5	16.95	14.22	0.96	0.97	0.99	0.97	2.3	1.8	1.7	17.3	6.3	10.7
30-10-2023	411	412.7	415.1	20.88	23.5	16.92	14.21	0.96	0.97	0.99	0.97	2.3	1.8	1.7	17.2	6.3	10.8
30-10-2023	411	412.4	414.7	20.85	23.5	16.98	14.21	0.96	0.97	0.99	0.97	2.3	1.8	1.8	17.4	6.3	10.7
30-10-2023	412	412.7	415.2	20.88	23.4	17.02	14.22	0.96	0.97	0.99	0.97	2.2	1.8	1.8	17.1	6.4	10.9
30-10-2023	411	412.3	414.8	20.88	23.4	16.97	14.19	0.96	0.97	0.99	0.97	2.3	1.8	1.7	17.2	6.3	10.8
30-10-2023	411	411.8	414.4	20.89	23.4	16.97	14.18	0.96	0.97	0.99	0.97	2.2	1.8	1.7	17.1	6.3	11.2
30-10-2023	411	412.2	414.5	20.87	23.4	16.99	14.19	0.96	0.97	0.99	0.97	2.3	1.8	1.7	17.2	6.4	10.7
30-10-2023	411	412.2	414.4	20.83	23.4	16.98	14.17	0.97	0.97	0.99	0.97	2.3	1.8	1.7	17	6.5	11
30-10-2023	411	412.4	414.6	20.81	23.6	16.91	14.21	0.97	0.97	0.99	0.97	2.3	1.8	1.7	16.9	6.5	10.7
30-10-2023	410	411.3	413.6	20.82	23.5	16.89	14.14	0.96	0.97	0.99	0.97	2.2	1.8	1.7	17	6.8	10.8
30-10-2023	411	412.3	414.6	20.79	23.8	16.94	14.27	0.96	0.97	0.99	0.97	2.3	1.7	1.7	17	6.9	10.6
30-10-2023	410	411.6	413.7	20.76	23.6	16.91	14.16	0.96	0.97	0.99	0.97	2.2	1.8	1.8	17.1	6.8	10.8
30-10-2023	409	410.8	412.8	20.8	23.5	16.84	14.12	0.96	0.97	0.99	0.97	2.3	1.8	1.8	17.2	7	10.4
30-10-2023	410	411.4	413.4	20.75	23.6	16.85	14.14	0.96	0.97	0.99	0.97	2.3	1.8	1.7	17.1	7	10.4
30-10-2023	410	411.6	414	20.72	23.5	16.93	14.16	0.96	0.97	0.99	0.97	2.3	1.8	1.8	17	6.8	10.3
30-10-2023	411	411.9	414.2	20.74	23.6	16.97	14.2	0.96	0.97	0.99	0.97	2.2	1.8	1.8	17	7.1	10.6
30-10-2023	410	411.3	413.5	20.76	23.7	16.95	14.19	0.96	0.97	0.99	0.97	2.2	1.7	1.8	17	7	10.2
30-10-2023	410	411.6	413.7	20.73	23.6	16.92	14.16	0.96	0.97	0.99	0.97	2.1	1.7	1.7	16.9	6.9	9.9
30-10-2023	410	411.5	413.5	20.72	23.6	16.81	14.14	0.97	0.97	0.99	0.97	2.1	1.7	1.7	16.7	6.8	9.4
30-10-2023	410	411.2	413	20.91	23.6	16.81	14.17	0.96	0.97	0.99	0.97	2.2	1.7	1.7	17.1	6.9	9.6
30-10-2023	410	411.1	413.6	20.92	23.6	16.82	14.19	0.96	0.97	0.99	0.97	2.2	1.7	1.8	17.1	7.3	9.4
30-10-2023	411	412.7	414.9	20.86	23.7	16.89	14.25	0.96	0.97	0.99	0.97	2.2	1.7	1.7	17.1	7	9.5
30-10-2023	411	412.1	414	20.86	23.6	16.85	14.2	0.96	0.97	0.99	0.97	2.3	1.7	1.7	17.2	6.9	10

2023																	
30-10-2023	410	411.8	413.7	20.94	23.6	16.85	14.21	0.96	0.97	0.99	0.97	2.2	1.7	1.7	17.5	6.8	9.8
30-10-2023	410	411.6	413.6	21	23.6	16.25	14.06	0.96	0.97	0.98	0.97	2.1	1.7	1.7	17.7	6.9	10.3
30-10-2023	410	411.7	413.6	21.03	23.7	15.88	13.97	0.96	0.97	0.98	0.97	2.2	1.8	1.7	17.9	7.1	10.9
30-10-2023	411	412.2	414.3	21.04	23.6	15.82	13.95	0.96	0.97	0.98	0.97	2.2	1.7	1.8	17.8	6.9	10.7
30-10-2023	412	413.4	415.5	21.02	23.6	15.85	14.01	0.96	0.97	0.98	0.97	2.2	1.8	1.8	17.7	6.9	10.5
30-10-2023	412	413.7	416.1	20.96	23.8	15.87	14.05	0.96	0.97	0.98	0.97	2.1	1.6	1.6	17.5	6.7	10.5
30-10-2023	412	413.2	415.4	20.97	23.6	15.8	13.99	0.96	0.97	0.98	0.97	2.1	1.5	1.6	17.6	6.5	10.2
30-10-2023	413	413.8	416	20.95	23.6	15.82	14	0.96	0.97	0.98	0.97	2.1	1.7	1.8	17.6	6.9	10.3
30-10-2023	412	412.8	415.1	20.91	23.4	15.87	13.93	0.96	0.97	0.98	0.97	2.2	1.7	1.8	17.7	6.5	10.8
30-10-2023	412	413	415.1	20.95	23.2	15.86	13.9	0.96	0.97	0.98	0.97	2.2	1.7	1.8	17.7	6.3	10.6
30-10-2023	412	412.8	415.3	21.01	23.2	16.15	13.98	0.96	0.97	0.98	0.97	2.2	1.7	1.8	18	6.2	10.8
30-10-2023	411	411.9	414.6	21.08	23.3	16.06	13.97	0.96	0.97	0.98	0.97	2.2	1.7	1.8	18.1	6.4	10.4
30-10-2023	411	412.5	414.2	21.12	23.3	15.96	13.95	0.96	0.97	0.98	0.97	2	1.4	1.6	17.9	6	10.5
30-10-2023	411	411.9	414.3	21.84	23.9	16.44	14.4	0.97	0.97	0.98	0.97	2.1	1.6	1.6	17.1	6.3	10.1
30-10-2023	411	411.6	414.2	26.07	28.3	19.75	17.17	0.98	0.97	0.98	0.97	2.1	1.7	1.6	16.1	11.5	14.7
30-10-2023	411	412.3	415.1	21.92	24	16.48	14.44	0.97	0.97	0.98	0.97	2.2	1.7	1.8	17.6	6.9	11.3
30-10-2023	411	413.2	415.5	21.22	23.3	16.12	14.03	0.96	0.97	0.98	0.97	2.3	1.8	1.7	18.4	6.1	10.6
30-10-2023	411	413.2	415.4	21.39	23.3	16.15	14.07	0.96	0.97	0.98	0.97	2.3	1.7	1.6	18.4	6	10.8
30-10-2023	411	412.6	414.4	22.77	24.6	16.94	14.91	0.97	0.97	0.98	0.97	2.1	1.5	1.4	16.1	6.5	11
30-10-2023	411	412.4	414.1	22.08	23.9	16.56	14.48	0.97	0.97	0.98	0.97	2.2	1.6	1.6	17.5	6.5	10.9
30-10-2023	411	412.5	414.8	21.79	23.5	16.56	14.32	0.97	0.97	0.98	0.97	2.3	1.7	1.7	18.3	6	10.4
30-10-2023	412	413.4	415.8	21.75	23.5	16.58	14.36	0.97	0.97	0.98	0.97	2.3	1.8	1.7	18.1	6.1	10.8
30-10-2023	411	412.7	415.1	21.62	23.6	16.56	14.3	0.96	0.97	0.98	0.97	2.3	1.8	1.7	18	5.9	11.1

30-10-2023	411	412.5	414.4	21.38	23.3	16.47	14.13	0.96	0.97	0.98	0.97	2.2	1.7	1.6	18	5.9	11
30-10-2023	411	412.1	414.1	24.16	26.3	18.49	15.98	0.97	0.97	0.98	0.97	2.1	1.7	1.5	15.7	8.4	12.3
30-10-2023	411	411.9	413.6	25.93	28	19.73	17.07	0.98	0.97	0.98	0.97	2.1	1.7	1.6	15.6	11.4	14.2
30-10-2023	410	411.5	413.4	25.48	27.4	19.35	16.75	0.98	0.97	0.98	0.98	2.2	1.6	1.6	15.3	10.4	13.5
30-10-2023	411	412	414.1	21.67	23.5	16.53	14.26	0.96	0.97	0.98	0.97	2.3	1.8	1.7	17.3	6.2	11.1
30-10-2023	410	411.8	413.9	21.39	23.3	16.46	14.11	0.96	0.97	0.98	0.97	2.3	1.8	1.6	18.5	6.2	11.1
30-10-2023	410	411.8	414.2	21.35	23.3	16.51	14.12	0.96	0.97	0.98	0.97	2.2	1.7	1.6	17.9	6	11
30-10-2023	410	411.7	414.2	22.21	24.2	17.14	14.7	0.97	0.97	0.98	0.97	2.2	1.7	1.6	17.2	6.3	11.3
30-10-2023	410	411.1	413.6	25.05	27	19.2	16.49	0.98	0.97	0.98	0.98	2.2	1.7	1.6	15.3	9.8	13
30-10-2023	410	411.1	413.6	24.02	26	18.44	15.86	0.98	0.97	0.98	0.98	2.2	1.6	1.6	14.7	8.2	11.8
30-10-2023	410	411.4	413.9	22.84	24.8	17.61	15.1	0.97	0.97	0.98	0.97	2.2	1.6	1.6	15.6	7.2	11.4
30-10-2023	411	411.8	414.1	21.26	23.1	16.62	14.08	0.96	0.97	0.98	0.97	2.2	1.7	1.7	17.9	6.2	11.2
30-10-2023	410	411.5	413.6	21.26	23.1	16.64	14.06	0.96	0.97	0.98	0.97	2.2	1.7	1.7	18.4	6	11.3
30-10-2023	410	411.3	413.4	21.29	23.1	16.52	14.04	0.96	0.97	0.98	0.97	2	1.5	1.6	17.9	5.9	10.9
30-10-2023	409	410.9	413	22.71	24.6	17.38	14.97	0.97	0.98	0.98	0.97	2.2	1.7	1.6	15.9	6.7	10.8
30-10-2023	409	410.4	412.8	21.83	23.7	16.72	14.36	0.97	0.97	0.98	0.97	2.2	1.7	1.7	17.3	6.4	10.9
30-10-2023	409	410.5	413.1	21.66	23.5	16.58	14.24	0.97	0.97	0.98	0.97	2.2	1.7	1.7	17.5	6.3	11.1
30-10-2023	410	411.1	413.6	21.69	23.5	16.5	14.25	0.97	0.97	0.98	0.97	2	1.5	1.6	17.6	5.9	11.1
30-10-2023	410	411.3	413.4	21.62	23.5	16.53	14.25	0.97	0.98	0.98	0.97	2	1.5	1.5	17.5	5.9	11.3
30-10-2023	410	411.6	413.6	21.21	23.1	16.51	14.02	0.96	0.97	0.98	0.97	2.2	1.6	1.6	17.9	6	11
30-10-2023	410	411.5	413.4	21.25	23	16.55	14.02	0.96	0.97	0.98	0.97	2	1.4	1.5	17.7	5.9	11
30-10-2023	409	411	413	21.32	23	16.47	13.99	0.96	0.97	0.98	0.97	2.1	1.4	1.6	18.2	6	10.9
30-10-2023	410	411.3	413.9	21.2	23.1	16.47	14.01	0.96	0.97	0.98	0.97	2.3	1.7	1.8	18	6.2	10.8
30-10-2023	409	410.8	413.5	21.19	23	16.48	13.97	0.96	0.97	0.98	0.97	2.3	1.7	1.7	17.9	6.2	10.9

2023																	
30-10-2023	410	411.9	414.1	21.41	23.2	16.5	14.12	0.96	0.97	0.98	0.97	2.3	1.8	1.6	18.1	6.1	11.1
30-10-2023	410	411.5	413.7	21.31	23.2	16.5	14.07	0.96	0.97	0.98	0.97	2.3	1.8	1.6	18.4	6.1	10.9
30-10-2023	410	411.4	414	22	23.3	16.54	14.28	0.97	0.97	0.98	0.97	2.1	1.4	1.4	17.5	6	11.5
30-10-2023	410	411.6	414.3	23.03	23.3	16.47	14.52	0.97	0.97	0.98	0.97	2.2	1.7	1.7	16.8	6.2	11.2
30-10-2023	411	411.9	414.4	22.23	23.2	16.53	14.33	0.97	0.97	0.98	0.97	2.3	1.7	1.7	17.3	6.2	11.2
30-10-2023	410	411.4	413.9	21.96	23.3	16.5	14.24	0.96	0.97	0.98	0.97	2.3	1.7	1.7	17.5	6.2	11.1
30-10-2023	410	410.9	413.4	25.56	27.5	19.59	16.79	0.97	0.97	0.98	0.97	2.2	1.7	1.7	16.2	10.4	14.1
30-10-2023	410	411.4	413.8	26.39	27.2	19.26	16.88	0.98	0.97	0.98	0.98	2.2	1.7	1.6	14.8	10.1	13.2
30-10-2023	410	411.6	413.8	26.47	27.1	19.24	16.89	0.98	0.97	0.98	0.98	2.2	1.6	1.7	14.7	10	13.1
30-10-2023	410	410.9	413.1	25.81	27	19.15	16.65	0.98	0.97	0.98	0.97	2.1	1.6	1.6	15.1	10	12.8
30-10-2023	410	410.9	413.2	25.11	26.7	19.13	16.43	0.98	0.97	0.98	0.98	2.1	1.6	1.6	15.3	9.7	12.6
30-10-2023	410	411.2	413.4	21.95	23.7	16.92	14.42	0.97	0.97	0.98	0.97	2.2	1.6	1.7	17.9	6.8	11.6
30-10-2023	410	411.6	413.8	21.12	23.2	16.6	14.06	0.96	0.97	0.98	0.97	2.2	1.6	1.7	18.1	6.1	11.5
30-10-2023	411	412.2	414.6	21.1	23.2	16.57	14.05	0.96	0.97	0.98	0.97	2.2	1.6	1.7	17.6	6.2	11.3
30-10-2023	411	412.3	414.6	21.07	23.2	16.63	14.08	0.96	0.97	0.98	0.97	2.2	1.7	1.7	17.4	6.2	10.8
30-10-2023	411	412	414.4	21.05	23.1	16.63	14.03	0.96	0.97	0.98	0.97	2.2	1.7	1.7	17.2	6.3	10.8
30-10-2023	411	412.1	414.5	21.92	23.9	17	14.57	0.97	0.97	0.98	0.97	2.1	1.6	1.7	15.6	6.1	10.4
30-10-2023	411	411.9	414.3	22.02	24.1	16.89	14.6	0.97	0.98	0.98	0.97	2.1	1.6	1.7	15.7	6.7	10.8
30-10-2023	411	412.1	414.7	21.52	23.5	16.54	14.26	0.97	0.97	0.98	0.97	2.2	1.7	1.8	16.9	6	11
30-10-2023	411	412.9	415.1	21.87	23.5	16.6	14.37	0.97	0.97	0.98	0.97	2.3	1.8	1.7	16.9	5.9	11.1
30-10-2023	411	412.8	414.8	22.32	23.5	16.69	14.55	0.98	0.97	0.98	0.98	2.3	1.8	1.7	16.8	5.9	11.2
30-10-2023	411	412.8	414.9	22.38	23.6	16.68	14.59	0.98	0.97	0.98	0.98	2.3	1.7	1.7	16.4	5.9	11.1
30-10-2023	411	412.8	414.9	21.88	23	16.6	14.32	0.98	0.97	0.98	0.98	2.2	1.6	1.8	16.7	6	10.8

30-10-2023	412	413	415.1	22.24	23.1	16.64	14.43	0.98	0.97	0.98	0.98	2.2	1.7	1.7	16.5	6	11.3
30-10-2023	411	412.9	414.4	23.22	23.9	16.96	14.95	0.98	0.97	0.98	0.98	2.2	1.7	1.7	15.7	6.1	11
30-10-2023	411	412.7	414.6	25.12	25.8	18.24	16.15	0.99	0.97	0.98	0.98	2.1	1.6	1.6	13.9	8.3	11.7
30-10-2023	411	412.8	414.7	23.92	24.7	17.41	15.41	0.99	0.98	0.98	0.98	2.1	1.6	1.7	13.9	6.5	10.5
30-10-2023	411	412.9	415.1	23.85	24.7	17.49	15.44	0.99	0.98	0.98	0.98	2.2	1.6	1.7	13.8	6.4	10.6
30-10-2023	412	413	415.4	23.44	24.4	17.23	15.2	0.99	0.98	0.98	0.98	2.1	1.6	1.7	14.5	6.3	10.7
30-10-2023	412	413.2	415.3	23.64	23.4	16.59	14.83	0.98	0.97	0.98	0.98	2.2	1.6	1.7	15.8	5.8	10.9
30-10-2023	411	413.1	414.9	25.2	25.1	17.64	15.85	0.99	0.97	0.98	0.98	2	1.4	1.5	14.6	7.1	11.3
30-10-2023	411	412.9	414.7	24	24	16.96	15.13	0.98	0.97	0.98	0.98	2.2	1.6	1.6	15.2	6.5	11.1
30-10-2023	412	413.1	415.1	22.42	23.1	16.65	14.47	0.98	0.97	0.98	0.98	2.3	1.7	1.7	16.9	6.1	11
30-10-2023	412	413.6	415.8	22.16	23.3	16.7	14.49	0.98	0.97	0.98	0.98	2.2	1.6	1.7	16.6	5.8	11.1
30-10-2023	412	414	415.9	21.98	23.2	16.67	14.42	0.98	0.97	0.98	0.98	2	1.5	1.6	16.7	5.8	10.9
30-10-2023	413	414.2	416.5	22	23.1	16.8	14.46	0.98	0.97	0.98	0.98	2	1.5	1.6	16.8	5.7	11.1
30-10-2023	413	414.2	416.5	21.98	23.2	16.75	14.45	0.98	0.97	0.98	0.98	2	1.6	1.7	17	5.8	11.1
30-10-2023	413	414.9	417	21.96	23.1	16.8	14.45	0.98	0.97	0.98	0.98	2.1	1.7	1.7	16.8	5.9	11.3
30-10-2023	413	415	416.9	22	23.3	16.8	14.52	0.98	0.97	0.98	0.98	2.1	1.7	1.7	16.9	5.9	11.5
30-10-2023	413	415.1	417.3	22.81	23.2	16.87	14.69	0.98	0.97	0.98	0.98	2.2	1.7	1.8	16.7	5.9	11.9
30-10-2023	413	414.9	416.8	23.29	23.2	16.89	14.81	0.98	0.97	0.98	0.98	2.2	1.7	1.8	16.6	5.8	12.2
30-10-2023	413	414.7	416.5	23.37	23.2	16.8	14.79	0.98	0.97	0.98	0.98	2.2	1.7	1.8	16.8	5.9	11.9
30-10-2023	413	413.9	416.1	23.47	23.1	16.73	14.75	0.98	0.97	0.97	0.97	2.2	1.7	1.8	17.3	5.8	11.9
30-10-2023	413	413.7	416.1	23.13	23.1	16.82	14.7	0.98	0.97	0.97	0.97	2.3	1.6	1.8	17.1	6.1	12.1
30-10-2023	413	413.7	416.2	22.54	23.3	16.86	14.61	0.98	0.97	0.98	0.98	2.2	1.6	1.7	17.2	5.8	11.6
30-10-2023	413	413.9	416.4	23.63	24.5	17.61	15.4	0.99	0.97	0.98	0.98	2.2	1.5	1.7	15.1	6.5	11.2
30-10-2023	413	414.3	416.4	22.68	23.3	16.79	14.67	0.98	0.97	0.98	0.98	2.2	1.6	1.8	16.5	5.6	11.7

2023																	
30-10-2023	414	414.8	418.3	22.45	22.9	16.85	14.57	0.98	0.97	0.98	0.98	2.2	1.6	1.7	16.7	5.9	11.3
30-10-2023	413	414.4	416.9	22.32	22	17.02	14.36	0.98	0.98	0.97	0.98	2.2	1.6	1.8	16.9	6.7	11.6
30-10-2023	413	414.6	417.8	22.74	22.4	17.8	14.79	0.98	0.98	0.98	0.98	2.2	1.6	1.7	15.8	6.8	10.7
30-10-2023	413	413.9	416.2	24.02	23.5	18.66	15.53	0.98	0.98	0.98	0.98	2.2	1.6	1.7	14.8	7.7	10.5
30-10-2023	413	414.1	416.4	22.87	22.3	17.91	14.81	0.98	0.98	0.98	0.98	2.2	1.6	1.8	15.6	6.7	10.1
30-10-2023	413	414.3	417	23.69	22.5	17.77	15.01	0.98	0.98	0.98	0.98	2.3	1.6	1.8	15.3	6.7	10.5
30-10-2023	413	414.1	416.5	23.21	21.9	17.66	14.71	0.98	0.98	0.98	0.98	2.3	1.6	1.9	16.3	6.8	10.4
30-10-2023	412	414.1	416.1	23.26	22	17.62	14.72	0.98	0.98	0.98	0.98	2.3	1.6	1.8	16.3	7	10.5
30-10-2023	413	414.3	416.7	23.23	21.9	17.66	14.71	0.98	0.98	0.98	0.98	2	1.4	1.7	16.4	6.7	10.4
30-10-2023	413	414.5	416.8	23.08	21.9	17.68	14.67	0.98	0.98	0.98	0.98	2.2	1.5	1.7	16.5	6.6	10.5
30-10-2023	413	414.5	416.9	23.21	21.9	17.74	14.72	0.98	0.98	0.98	0.98	2.3	1.6	1.8	16.5	6.8	10.6
30-10-2023	414	415	417.7	22.46	21.9	17.66	14.57	0.98	0.98	0.98	0.98	2.2	1.5	1.8	16.8	6.8	10.5
30-10-2023	413	414.9	417	22.05	21.9	17.72	14.46	0.98	0.98	0.98	0.98	2.1	1.4	1.7	16.4	6.6	10.3
30-10-2023	414	415.3	418	21.97	21.9	17.73	14.47	0.98	0.98	0.98	0.98	2.1	1.4	1.6	16.8	6.7	10.4
30-10-2023	414	415.2	417.4	22.04	22	17.75	14.49	0.98	0.98	0.98	0.98	2.2	1.6	1.8	16.6	6.8	10.3
30-10-2023	414	415.5	417.8	22.13	21.9	17.73	14.5	0.98	0.98	0.98	0.98	2.3	1.6	1.8	16.9	6.7	10.7
30-10-2023	414	415.8	418.2	22.23	21.9	17.73	14.54	0.98	0.98	0.98	0.98	2.2	1.6	1.8	16.9	6.8	10.5
30-10-2023	414	415.6	417.6	22.3	21.8	18.58	14.72	0.98	0.98	0.98	0.98	2.3	1.6	1.8	17.2	6.9	9.9
30-10-2023	414	415.7	418.2	23.22	21.9	18.75	15.01	0.98	0.98	0.98	0.98	2.2	1.6	1.8	16.7	6.6	9.8
30-10-2023	414	415.6	417.8	22.99	22	18.68	14.96	0.98	0.98	0.98	0.98	2.3	1.6	1.8	16.6	6.9	10
30-10-2023	415	415.8	418.2	22.36	21.9	18.62	14.8	0.98	0.98	0.98	0.98	2.2	1.6	1.8	16.8	6.8	9.7
30-10-2023	415	416	418.2	22.29	21.9	18.66	14.78	0.98	0.98	0.98	0.98	2.2	1.7	1.8	16.8	6.8	9.8
30-10-2023	415	416.1	418.5	22.15	21.9	18.7	14.77	0.98	0.97	0.98	0.98	2.2	1.6	1.8	17.1	6.8	10

30-10-2023	415	416.2	418.6	22.19	21.9	18.62	14.77	0.98	0.98	0.98	0.98	2.2	1.7	1.9	16.8	6.8	9.8
30-10-2023	415	416.3	418.5	22.2	22	18.56	14.78	0.98	0.98	0.98	0.98	2.2	1.6	1.8	16.8	6.7	9.7
30-10-2023	415	416	418.1	25.19	25.1	20.75	16.72	0.98	0.97	0.98	0.98	2.1	1.6	1.8	15.1	9.4	11.2
30-10-2023	414	415.3	417.4	26.37	26.1	21.5	17.41	0.99	0.97	0.98	0.98	2.1	1.6	1.7	14.5	11.5	11.9
30-10-2023	414	415.5	417.5	25.96	25.9	21.27	17.22	0.99	0.97	0.98	0.98	1.9	1.3	1.5	15.1	11.3	11.6
30-10-2023	414	415.8	418.1	23.33	23.3	19.42	15.57	0.98	0.98	0.98	0.98	2.1	1.5	1.7	15.6	8.2	10.4
30-10-2023	415	415.8	418.1	22.04	21.9	18.61	14.72	0.98	0.98	0.98	0.98	2.2	1.6	1.7	16.7	6.7	9.8
30-10-2023	414	415.8	418	22	21.9	18.66	14.71	0.98	0.98	0.98	0.98	2.2	1.6	1.8	16.8	6.5	9.9
30-10-2023	415	415.9	418.2	22.25	22.2	18.66	14.86	0.98	0.98	0.98	0.98	2.2	1.6	1.7	16.7	6.3	9.6
30-10-2023	415	416.5	418.7	23.46	23.5	19.4	15.68	0.99	0.98	0.98	0.98	2.1	1.5	1.7	14.8	7.3	9.6
30-10-2023	416	416.9	419.2	22.23	22.3	18.66	14.91	0.98	0.98	0.98	0.98	2.2	1.6	1.8	16.6	6.6	10
30-10-2023	415	416.6	418.6	21.86	21.9	18.68	14.72	0.98	0.98	0.98	0.98	2.2	1.6	1.8	16.8	6.5	9.9
30-10-2023	415	416.7	418.5	21.87	22	18.61	14.74	0.98	0.98	0.98	0.98	2.2	1.6	1.8	16.6	6.5	9.8
30-10-2023	415	416.9	419	21.82	21.9	18.59	14.69	0.98	0.97	0.98	0.98	2.1	1.6	1.8	16.9	6.7	9.8
30-10-2023	415	416.9	419	21.71	21.8	18.59	14.65	0.98	0.97	0.98	0.98	2.1	1.6	1.8	16.6	6.4	9.6
30-10-2023	416	417	419	21.75	21.8	18.67	14.66	0.98	0.97	0.98	0.98	2.1	1.6	1.8	16.4	6.4	9.9
30-10-2023	416	417.2	419.7	21.79	21.8	18.65	14.69	0.98	0.97	0.98	0.98	2.1	1.6	1.7	16.5	6.3	9.9
30-10-2023	416	417.4	419.6	21.81	22.1	18.69	14.77	0.98	0.97	0.98	0.98	2.2	1.6	1.7	16.8	6.6	10.1
30-10-2023	416	417.2	419.4	21.89	22	18.67	14.77	0.98	0.97	0.98	0.98	1.9	1.4	1.6	16.6	6.4	9.8
30-10-2023	416	417	419.1	21.77	21.9	18.61	14.7	0.98	0.97	0.98	0.98	1.9	1.3	1.5	16.5	6.4	9.7
30-10-2023	415	416.9	419	21.84	21.8	18.64	14.69	0.98	0.97	0.98	0.98	2	1.4	1.6	16.5	6.4	9.7
30-10-2023	415	416.9	419	21.77	22	18.6	14.7	0.98	0.98	0.98	0.98	2.1	1.5	1.6	16.6	6.5	9.5
30-10-2023	415	416.6	418.7	21.8	22	18.65	14.7	0.98	0.98	0.98	0.98	2.2	1.6	1.7	16.9	6.5	9.7
30-10-2023	415	416.7	418.7	21.8	21.8	18.65	14.67	0.98	0.97	0.98	0.98	2.2	1.6	1.7	17	6.5	9.5

2023																	
30-10-2023	415	416.8	418.7	22.23	22.3	18.81	14.94	0.98	0.98	0.98	0.98	2.2	1.6	1.7	16.6	6.7	9.8
30-10-2023	414	416.3	418	26.64	26.9	21.85	17.74	0.99	0.97	0.98	0.98	2.1	1.6	1.6	14.9	12.1	12.5
30-10-2023	415	416.3	418.1	24.57	24.5	20.24	16.34	0.99	0.98	0.98	0.98	2	1.4	1.5	14.4	9.3	11.4
30-10-2023	415	416.1	418	23.05	21.9	18.56	14.94	0.98	0.98	0.98	0.98	1.9	1.3	1.5	15.9	6.2	9.8
30-10-2023	415	416.3	418.2	22.89	22	18.56	14.92	0.98	0.98	0.98	0.98	2.1	1.5	1.6	16.5	6.5	9.7
30-10-2023	414	415.7	417.6	23.91	23.1	19.22	15.6	0.98	0.98	0.98	0.98	2.2	1.5	1.6	14.7	7.3	9.6
30-10-2023	414	415.4	417.6	22.28	22	18.56	14.8	0.98	0.98	0.98	0.98	2.2	1.6	1.7	16.2	6.3	9.3
30-10-2023	414	415.5	417.6	22.03	22.1	18.63	14.76	0.98	0.98	0.98	0.98	2.1	1.6	1.7	16.3	6.4	9.5
30-10-2023	414	415.2	417.4	21.77	21.8	18.61	14.6	0.98	0.98	0.98	0.98	2	1.4	1.6	16.4	6.2	9.4
30-10-2023	414	415.6	417.7	21.81	21.8	18.49	14.59	0.98	0.98	0.98	0.98	2	1.5	1.6	16.4	6.3	9.1
30-10-2023	414	415.6	417.6	22.74	22.6	18.95	15.15	0.98	0.98	0.98	0.98	2.1	1.5	1.6	15.1	6.6	8.8
30-10-2023	414	415.4	417.5	22.78	22.7	18.94	15.17	0.98	0.98	0.98	0.98	2.1	1.6	1.6	15.4	7.1	9.1
30-10-2023	414	415.3	417.5	22.25	22.2	18.49	14.81	0.98	0.98	0.98	0.98	2.1	1.6	1.7	16.5	6.4	9.3
30-10-2023	414	414.9	417.1	22.2	22.1	18.49	14.77	0.98	0.98	0.98	0.98	2.1	1.6	1.6	16.7	6.2	9.5
30-10-2023	414	415.3	417.4	22.18	22.1	18.65	14.79	0.98	0.98	0.98	0.98	2	1.5	1.6	16.4	6.2	9.8
30-10-2023	415	416.1	418.4	21.94	21.8	18.67	14.69	0.98	0.98	0.98	0.98	1.9	1.5	1.6	16.5	6.2	9.9
30-10-2023	415	416.4	418.6	21.89	22	18.73	14.75	0.98	0.98	0.98	0.98	2.1	1.7	1.7	16.6	6.4	9.7
30-10-2023	416	416.9	419.3	21.8	21.9	18.81	14.73	0.98	0.97	0.98	0.98	2.2	1.6	1.7	16.7	6.3	9.8
30-10-2023	416	417.1	419.3	21.92	21.8	18.65	14.71	0.98	0.97	0.98	0.98	2.2	1.6	1.7	16.8	6.4	9.8
30-10-2023	416	416.9	419.2	21.94	21.8	18.67	14.7	0.98	0.97	0.98	0.98	2.2	1.7	1.7	16.9	6.3	9.8
30-10-2023	416	416.9	419.4	21.92	21.8	18.68	14.7	0.98	0.97	0.98	0.98	2.2	1.7	1.7	16.7	6.3	9.7
30-10-2023	416	417	419.7	21.89	21.9	18.69	14.73	0.98	0.97	0.98	0.98	2.2	1.6	1.7	16.5	6.3	9.8
30-10-2023	416	417.3	420	21.85	21.9	18.64	14.73	0.98	0.97	0.98	0.98	2.1	1.6	1.6	16.4	6.4	9.7

30-10-2023	416	417.5	420.2	21.78	21.8	18.68	14.71	0.98	0.97	0.98	0.98	2.1	1.6	1.6	16.5	6.4	9.7
30-10-2023	416	417.9	420.4	22.74	22.7	19.16	15.29	0.98	0.98	0.98	0.98	2.1	1.5	1.6	15.7	6.6	9.7
30-10-2023	416	417.5	419.8	26.54	26.8	22.01	17.78	0.99	0.97	0.98	0.98	2	1.5	1.6	14.8	12.5	12.7
30-10-2023	416	417.6	420	25.54	25.7	21.15	17.13	0.99	0.97	0.98	0.98	2	1.5	1.5	14	10.8	11.4
30-10-2023	416	417.6	420.1	25.33	25.4	21.07	17.01	0.99	0.97	0.98	0.98	2	1.5	1.6	13.7	10.6	11.2
30-10-2023	417	418	420.5	25.3	25.4	21.03	16.98	0.99	0.97	0.98	0.98	1.8	1.3	1.4	14.7	10.7	11.7
30-10-2023	418	419.3	422	25.23	25.3	20.92	16.99	0.99	0.97	0.98	0.98	2	1.5	1.5	13.7	10.3	11.7
30-10-2023	418	419.5	422.2	24.9	25	20.65	16.79	0.99	0.97	0.98	0.98	2.1	1.5	1.6	13.6	10.1	10.7
30-10-2023	418	419.8	422.4	21.99	22.1	18.75	14.93	0.98	0.97	0.98	0.98	2.2	1.6	1.7	16.2	6.2	9.5
30-10-2023	418	420	422.4	21.78	21.9	18.75	14.83	0.98	0.97	0.98	0.98	2.2	1.6	1.7	16.4	6.1	9.5
30-10-2023	418	419.4	421.8	21.75	21.9	18.69	14.78	0.98	0.97	0.98	0.98	2.1	1.6	1.7	16.3	6.2	9.3
30-10-2023	418	419	421.4	22.32	22.5	18.88	15.13	0.98	0.98	0.98	0.98	2.2	1.6	1.7	15.6	6.3	9.3
30-10-2023	417	418.5	420.9	23.13	23.2	19.38	15.59	0.99	0.98	0.98	0.98	2	1.6	1.6	14.4	7.4	9.6
30-10-2023	417	418.4	420.9	22.17	22.2	18.64	14.94	0.98	0.98	0.98	0.98	2.1	1.6	1.6	15.8	6.3	9.2
30-10-2023	417	418.6	421	22.09	22.2	18.7	14.93	0.98	0.98	0.98	0.98	2.2	1.6	1.7	16.1	6.3	9.4
30-10-2023	417	418.5	420.8	21.91	22.1	18.62	14.82	0.98	0.97	0.98	0.98	2.2	1.6	1.7	16.3	6.4	9.4
30-10-2023	417	418.1	420.4	21.82	21.9	18.67	14.74	0.98	0.97	0.98	0.98	2.1	1.6	1.7	16.3	6.2	9.4
30-10-2023	416	418	420.4	21.8	21.9	18.63	14.72	0.98	0.97	0.98	0.98	2.1	1.6	1.7	16.2	6.3	9.3
30-10-2023	416	418	420.4	21.84	21.8	18.63	14.72	0.98	0.97	0.98	0.98	2.1	1.6	1.7	16.3	6	9.4
30-10-2023	416	417.8	420.2	21.73	21.8	18.61	14.68	0.98	0.97	0.98	0.98	2.2	1.6	1.7	16.5	6.2	9.6
30-10-2023	416	417.7	420	21.74	21.7	18.66	14.66	0.98	0.97	0.98	0.98	2.2	1.6	1.7	16.7	6.2	9.4
30-10-2023	416	417.1	419.6	21.77	21.6	18.62	14.62	0.98	0.97	0.98	0.98	2.2	1.6	1.6	17	6.2	9.8
30-10-2023	416	417.3	419.8	21.78	21.6	18.63	14.63	0.98	0.97	0.98	0.98	2.2	1.6	1.7	16.7	6.2	9.6
30-10-2023	416	417.3	419.8	21.92	21.7	18.56	14.67	0.98	0.97	0.98	0.98	2	1.4	1.5	16.3	6.6	9.4

2023																	
30-10-2023	415	416.3	418.5	21.77	21.6	18.37	14.53	0.98	0.97	0.98	0.98	2.1	1.6	1.7	16.3	6.2	9.9
30-10-2023	417	417.7	420.5	21.74	21.6	18.16	14.51	0.98	0.97	0.98	0.98	2.2	1.6	1.7	16.3	5.9	10.6
30-10-2023	416	417.3	420.2	21.74	21.6	18.46	14.58	0.98	0.97	0.98	0.98	2.2	1.6	1.7	16.2	6	10.1
30-10-2023	416	416.8	419.7	21.93	21.7	18.4	14.6	0.98	0.97	0.98	0.98	2.2	1.6	1.7	16.9	6.1	10.5
30-10-2023	416	416.6	419.5	21.87	21.7	18.43	14.58	0.98	0.97	0.97	0.98	2.2	1.6	1.6	16.5	5.8	10.4
30-10-2023	416	416.6	419.5	21.73	21.7	18.51	14.57	0.98	0.97	0.97	0.98	2	1.4	1.5	16.4	5.8	10.8
30-10-2023	416	416.7	419.4	22.81	21.7	18.44	14.82	0.98	0.97	0.97	0.98	2.1	1.6	1.7	15.7	6	10.5
30-10-2023	415	416.2	418.9	22.77	21.7	18.42	14.79	0.98	0.97	0.97	0.98	2.2	1.6	1.8	15.9	6	10.5
30-10-2023	415	415.8	418.4	22.69	21.9	17.9	14.68	0.98	0.97	0.97	0.98	2.2	1.7	1.8	16.1	6.4	10.5
30-10-2023	415	416.2	418.7	22.6	21.9	17.85	14.66	0.98	0.97	0.97	0.98	2.3	1.7	1.8	16.1	6.4	10.9
30-10-2023	415	416.3	419	21.92	21.8	17.83	14.48	0.98	0.97	0.97	0.98	2.2	1.6	1.7	16	6.3	10.4
30-10-2023	416	416.6	419.3	21.8	21.7	17.83	14.43	0.98	0.97	0.97	0.98	2.2	1.6	1.7	16.8	6.3	10.8
30-10-2023	417	417.4	420.3	21.76	21.9	18.02	14.53	0.98	0.97	0.97	0.98	2.2	1.6	1.7	16.7	6.5	11.9
30-10-2023	417	417.4	420.4	21.74	22	18.05	14.58	0.98	0.97	0.97	0.98	2.2	1.6	1.7	16.2	6.4	11.7
30-10-2023	417	417.8	420.7	21.81	22.1	18.12	14.64	0.98	0.97	0.97	0.98	2.1	1.5	1.7	15.9	6.4	11.7
30-10-2023	417	417.8	420.7	21.93	22	17.99	14.62	0.98	0.97	0.97	0.98	2.1	1.7	1.7	16	6.5	11.8
30-10-2023	417	417.9	420.8	21.84	21.9	18.02	14.58	0.98	0.97	0.97	0.98	2.2	1.7	1.8	16.1	6.5	11.9
30-10-2023	417	418.1	420.8	21.83	22.1	18.06	14.64	0.98	0.97	0.97	0.98	2.2	1.7	1.8	16.3	6.5	12
30-10-2023	417	417.9	420.5	21.85	22	18.05	14.62	0.98	0.97	0.97	0.98	2.2	1.7	1.8	16.3	6.6	11.8
30-10-2023	417	417.9	420.4	21.93	22.1	18.03	14.63	0.98	0.97	0.97	0.98	2.2	1.7	1.8	16.3	6.5	11.9
30-10-2023	417	417.6	420.2	21.82	22.1	18	14.59	0.98	0.97	0.97	0.98	2.2	1.7	1.8	16	6.6	11.8
30-10-2023	417	417.8	420.3	21.89	22	18.04	14.61	0.98	0.97	0.97	0.98	2.2	1.7	1.8	16.8	6.6	11.8
30-10-2023	417	417.6	420	21.85	22	18.04	14.6	0.98	0.97	0.97	0.98	2.2	1.7	1.8	16.2	6.5	11.8

30-10-2023	417	417.6	420	21.77	22.1	18.04	14.6	0.98	0.97	0.97	0.98	2.1	1.6	1.8	16	6.8	11.8
------------	-----	-------	-----	-------	------	-------	------	------	------	------	------	-----	-----	-----	----	-----	------

5.2 Variation in Electrical Parameters

Now we present the variation in various Electrical parameters as under.

5.2.1 Voltage

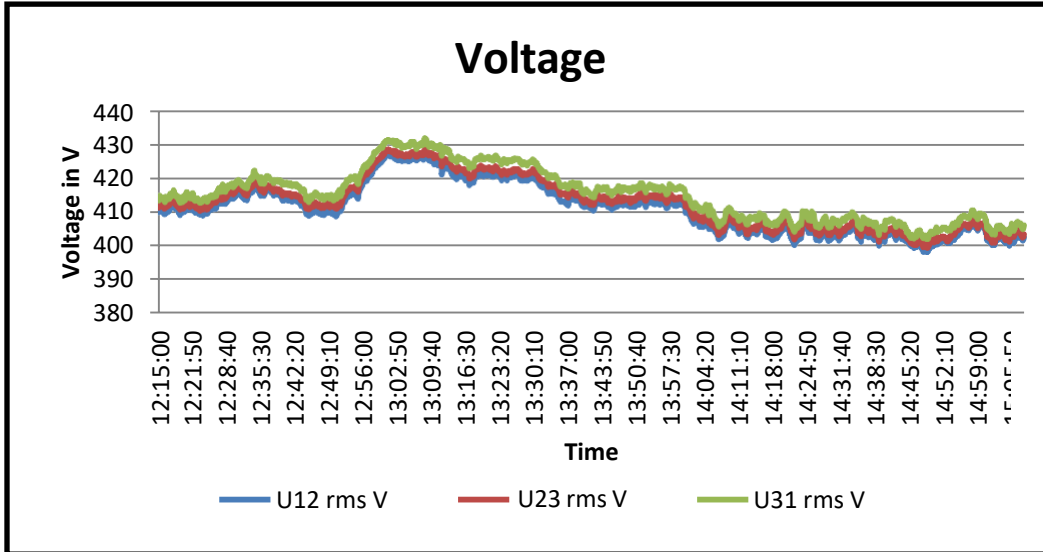

Average voltage is around 413.0 V of transformer.

5.2.2 Current

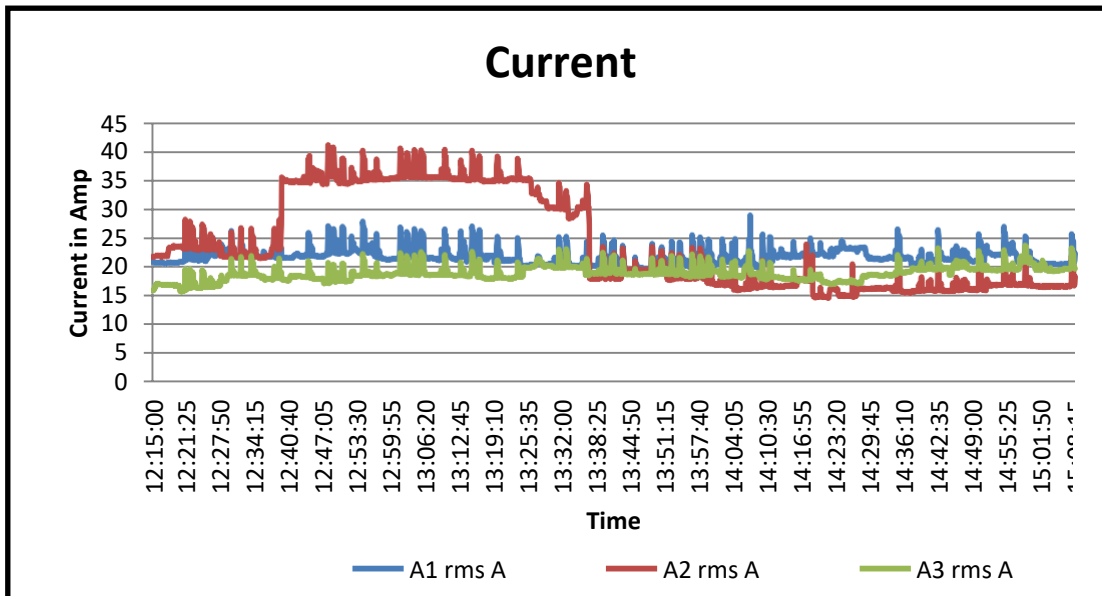

Current variation is load variation. Average current is around 21.62A.

5.2.3 Total Active power (kW)

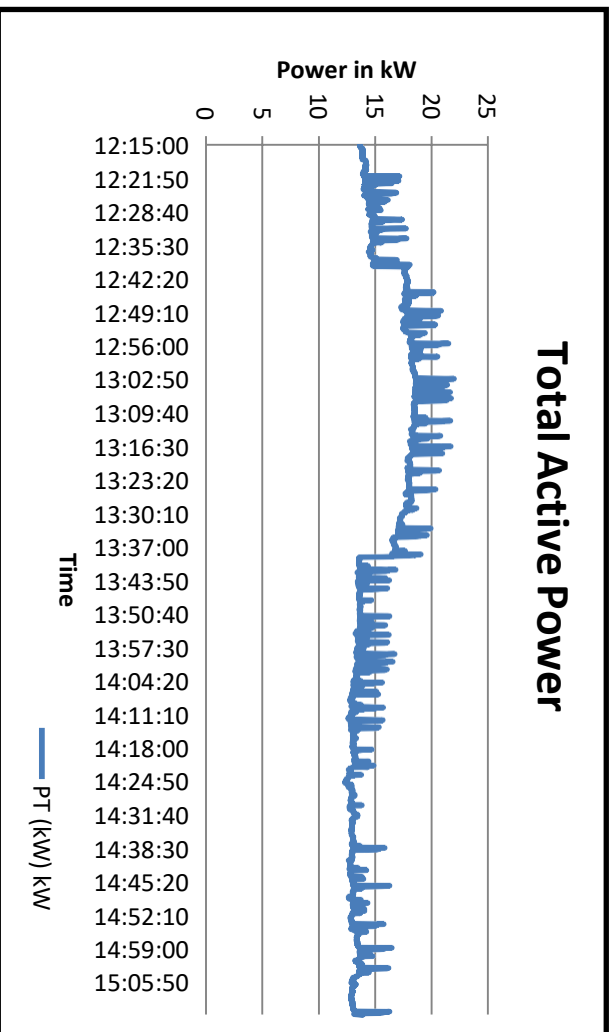

Variation in load demand can be observed in the graph. Average power consumption of the facility is around 15.23 kW.

5.2.4 Power factor

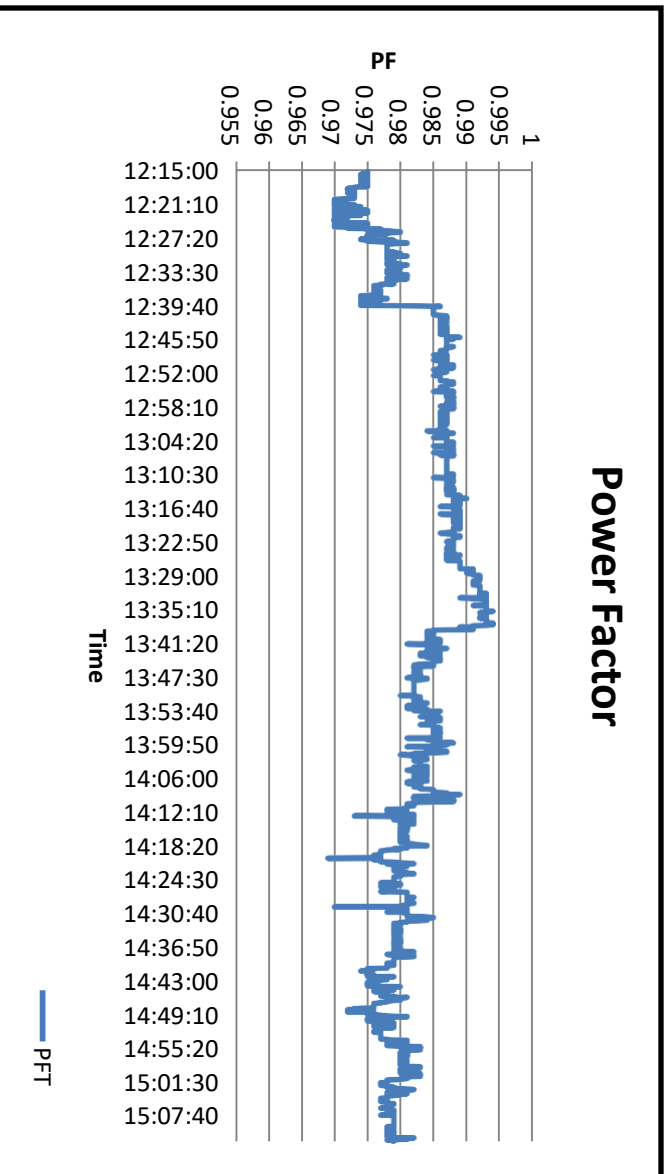

Average power factor is 0.982.

5.2.5 Voltage THD%

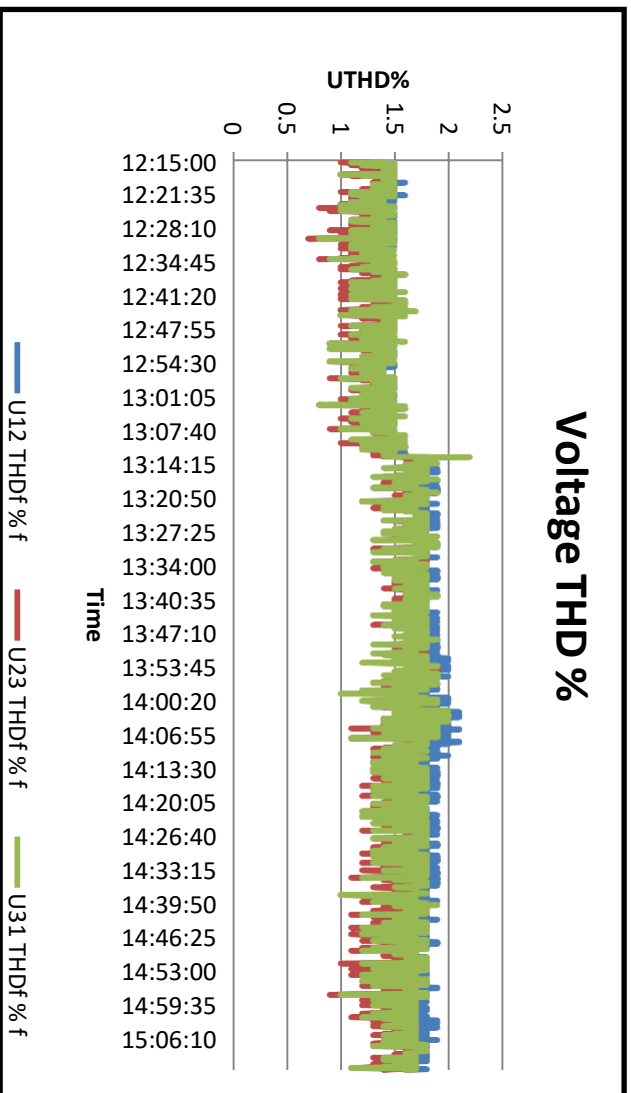

Average voltage harmonic distortion is 1.55 %.

5.2.6 Current THD%

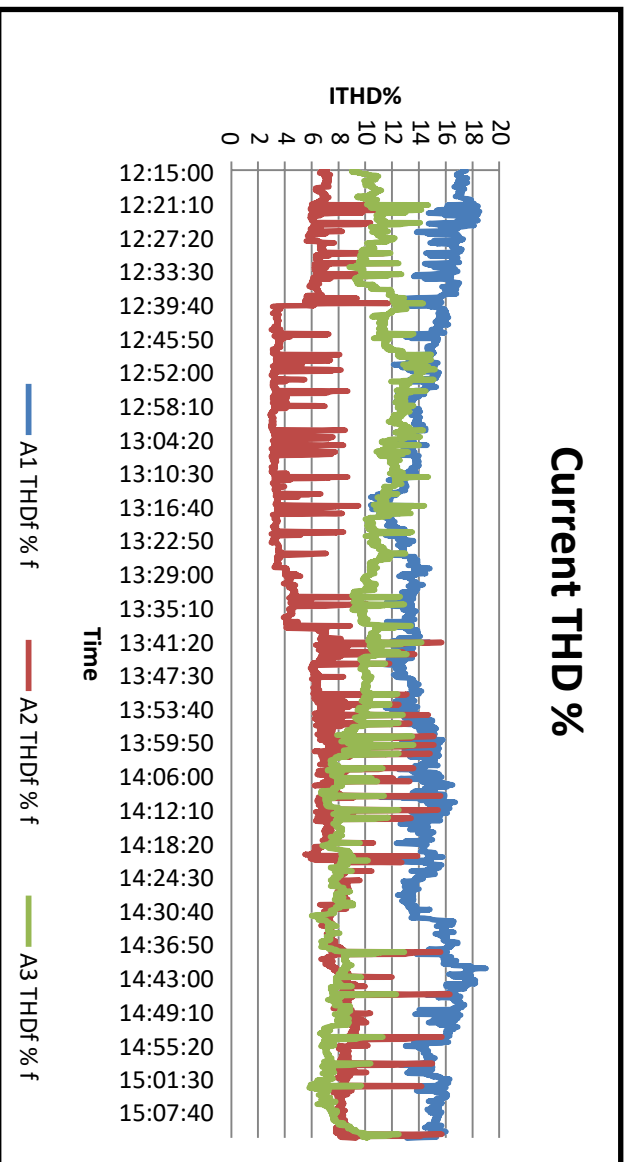

Average current harmonic distortion is 10.32% whereas peak is 19%.

CHAPTER-VI

SCOPE OF RENEWABLE ENERGY AND EFFICIENT FACILITY AT COLLEGE CAMPUS

6.1 Installation of 50 kWp Solar PV roof Top on Bharati Vidyapeeth's College of Fine Arts building:

During the Audit, it was revealed that the College has ample space on the Terrace but top two floors under construction. It is proposed once construction completes Solar Photovoltaic roof top with net meter of capacity **50 kWp can be installed**. The system will cater the Day load Demand of the College.

We furnish herewith the saving potential as under

No	Particulars	Value	Unit
1	Installed Capacity of Solar PV Pack	50	kWp
2	Daily working period	6	Hrs./Day
3	Daily units generated	300	kWh/Day
4	Annual working days	280	Day/annum
5	Annual saving in Grid Electrical Energy	84000	kWh/annum
6	Annual CO ₂ saving potential	67.2	MT/Annum
7	Present Energy Charges	10	Rs/kWh
8	Annual monetary Gain	840000	Rs/Annum
9	Investment required	22,50000	Rs lump sum
10	Payback period	2.67	Years

6.2 Solar powered light for hoarding

Lighting solar systems are the fixed installations designed for domestic as well as small scale commercial application. The component of the solar lighting system includes solar PV module (solar cells), charge controller, solar battery and lighting system (lamps & fans). Modules are installed in the open on roof/terrace - exposed to sunlight and the charge controller and battery are kept inside a protected place in the house.



Figure-1: Solar powered light for Hoarding

This system comes with multiple benefits such as:

- **Economical:** Since the sun provides energy free of charge, 30% power savings on the electricity bill can be availed with longer back up lighting system at zero running cost.
- **Non-Polluting:** Powered by the sun's renewable energy, the system is energy neutral and an absolutely clean source of illumination. 1kWp solar installation reduces 1/2 ton of CO₂ (carbon dioxide) per annum.
- **No Maintenance:** The system has few moveable parts - reducing the risk of breakage. Once installed, it lasts for long time and requires little attention.

This system can be used to power the huge hoardings in the college campus.

Solar powered hoarding lighting system proposed will provide a better, faster, cheaper (and cleaner) alternative with solar. Since this product competes with diesel or conventional fuels, we needed to ensure we beat the cost of a diesel solution. In order to achieve that with solar, we consider the following system:

1. Highly Efficient Solar Panel

2. Charge Controllers with MPPT Technology – increases solar electricity production by up to 30% compared to conventional charge controllers

3. LED Projection Light - consumes 10-times less electricity compared to conventional bulbs, and has a 50,000 hour warranty.

Features:

- Auto on off

- 4 Days Battery Back Up
- Robust housing
- Weather proof

With this entire put together, we ended up with systems that provide 6 hours of lighting each night with 4 -lamp system to light up boards up to 15'x30', and a 8-lamp system to light larger boards up to 20'x40'. More importantly, with these options, payback of the system will come around 2.5 years. This system provides a way to reduce the lightings costs, get rid of all the operational hassles of owning a diesel generator, plus brand benefits from being "green" with the use of renewable energy like solar powered light hoarding board.

6.3 Solar charging stations

Solar cell phone chargers use solar panels to charge cell phone batteries. They are an alternative to conventional electrical cell phone chargers and in some cases can be plugged into an electrical outlet. Solar mobile charger is a device which can charge mobile phones using solar radiation. Its major component is a compact solar panel. This solar panel traps solar energy and produces an output voltage. But, since the light radiations falling on the solar panel can vary, the output voltage becomes unstable. For charging a mobile phone, stable voltage is required. So, to make the output voltage stable and regulated, voltage regulator circuit along with the solar panel is used.

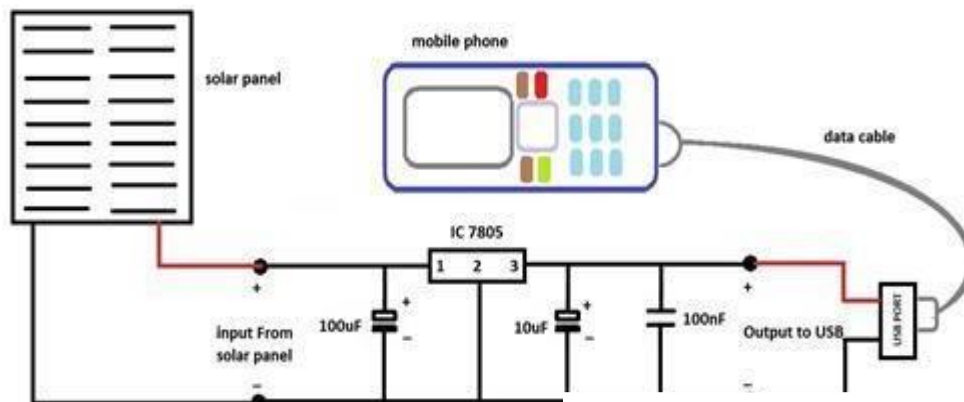

Figure-4: Solar charging Stations

Most of the mobile phones have computer connectivity via USB cable. USB port establishes 4 connection terminals. The connection terminals at the two extreme ends are the supply terminals. In a female USB connector (port via which we plug in USB devices to computer), these terminals carry 5V DC. When a mobile phone is connected to the USB port of a computer, it utilizes this 5V supply to recharge battery. This feature is used in a solar mobile charger. It converts and regulates solar energy to 5V DC and the output will be available through the female USB connector. To this connector, we can easily connect a mobile phone via data cable.

Chapter VII

SUGGESTIONS AND RECOMMENDATIONS

Following Energy Conservation Opportunities and actions on the basis of energy audit are suggested to implement in the campus on the basis of funds availability and institute preferences.

a) Energy Audit: Energy Conservation opportunities:

- Energy efficient tubes and fans can be replaced. Already the phasing out of old tubes has been undertaken during regular maintenance practices.
- Installation of 50 kW solar roof top system as ample space available on the roof of the college building. At present top floor construction is going on, Once it is over, roof area can be used for the installation of solar roof top. As sanctioned load is 291kW, the solar roof top of 50 kW capacity with net meter can be installed in the college campus to meet the requirement of electricity.
- Installation of Solar powered light for hoarding.
- Installation of 05 Nos. solar mobile phone charging stations in the college campus.
- Water management system must be in place. Overhead tanks can be with float control and Time of the day (TOD) can be implemented for water pumping for filling the overhead water tanks.

Environmental and Green Audit Report

of

Bharati Vidyapeeth's College of Fine Arts

Bharati Vidyapeeth Campus, Pune-Satara Road, Dhankawadi, Pune – 411043



Auditing Agency –
Prathamesh Energy Solution,
A-302, Shiv Unnati Residency,
Kalepadal, Hadapsar
Pune- 411 028

Prathamesh Energy Solution

A-302, Shiv Unnati residency, Kalepadal, Hadapsar, Pune-411028

Ref: PES/BVCOFA/2023-24/23

Date: 16/10/2023

To,

The Principal

Bharati Vidyapeeth's

College of Fine Arts

Pune-Satara Road, Dhankawadi, Pune – 411043

Sub: Submission of Report on Environmental and Green Audit of College Campus

Respected Sir,

Please find enclosed herewith the report

Thanking you

Yours faithfully

For Prathamesh Energy Solution

Authorized Signatory

Prathamesh Energy Solution

A-302, Shiv Unnati Residency, Kalepadal, Hadapsar, Pune 411028

Ref: EC/BVCOFA /23-24/20

CERTIFICATE

This is to certify that we have conducted Environmental and Green Audit at **Bharati Vidyapeeth's College of Fine Arts, Pune-Satara Road, Dhankawadi, Pune**, in the Academic year 2023-24

. The College has adopted following Energy Efficient practices:

- Usage of Energy Efficient LED Fittings
- Maximum usage of Day Lighting
- Green Campus
- Rain water Harvesting system

We appreciate the support of Management, involvement of faculty members and students in the process of making the Campus Energy Efficient.

For,

Prathamesh Energy Solution,

Certificate of Registration

This is to Certify that
Environmental Management System of

PRATHAMESH ENERGY SOLUTION

A-302, SHIV UNNATI RESIDENCY, KALEPADAL, HADAPSAR, PUNE-411028,
MAHARASHTRA, INDIA.

has been assessed and found to conform to the requirements of
ISO 14001:2015
for the following scope :

CONSULTANCY SERVICES FOR ENERGY AUDIT, GREEN AUDIT AND ENVIRONMENTAL
AUDIT IN EDUCATIONAL INSTITUTIONS AND OTHER ORGANIZATIONS & SUBMISSION OF
AUDIT CERTIFICATE AND REPORT.

Certificate No	: 23EELA98	Issuance Date	: 09/06/2023
Initial Registration Date	: 09/06/2023	Date of Expiry	: 08/06/2026
1st Surve. Due	: 09/05/2024	2nd Surve. Due	: 09/05/2025



Demu..
Director

Magnitude Management Services Pvt. Ltd.

Third Floor, A-60, Sector-2, Noida, Gautam Budh Nagar, U.P.-201301, India
e-mail: info@mmscertification.com, website: www.mmscertification.com

* Subject to Successful Surveillance Audit and case surveillance audit is not allowed to be conducted, this certificate shall be suspended/withdrawal.

Certificate Verification: Please Re-check the validity of certificate at <http://www.mmscertification.com/activeclients.aspx> or www.mmscertification.com at Active Clients.
Certificate is the property of Magnitude Management Services Pvt. Ltd. and shall be returned immediately when demanded



INDEX

Sr. No	Particulars	Page No
I	Acknowledgement	7
II	Executive Summary	8
III	Abbreviations	10
1	Environment and Green Audit: Introduction	11
2	Green Audit for AY-2023-24	12
	1. Plantation in the campus	12
	2. Carbon foot-printing	16
	3. Usage of renewable energy at college campus	19
	4. Illumination in class rooms	22
	5. Water Audit and Rain water harvesting	23
	6. Waste disposal	27
3	Suggestions and Recommendations	32

ACKNOWLEDGEMENT

We at Prathamesh Energy Solution, Pune, express our sincere gratitude to the management and Principal of Bharati Vidyapeeth's College of Fine Art, Dhankawadi, Pune for awarding us the assignment of Energy Audit of their College campus located at Pune-Satara Road, Dhankawadi, Pune.

We are very much thankful to

- Dr. Anupama Patil, Principal, BVCoFA, Dhankawadi, Pune
- Mr. Rupesh Pawar, Vice- Principal (Administration), BVCoFA, Dhankawadi, Pune
- Mrs. Mugdha Kale, Vice-Principal (Academics), BVCoFA, Dhankawadi, Pune
- Mr. Sagar Pansare, Coordinator & Assistant Professor, BVCoFA, Dhankawadi, Pune
- Mr. Sudhir Pawar, Coordinator & Assistant Professor, BVCoFA, Dhankawadi, Pune

for giving us opportunity to conduct detailed energy audit of the institute and provide all the required data and information promptly for the smooth conduction of detailed energy and green audit.

We are also thankful to various Heads of Departments, IQAC Coordinator & other Staff members for helping us during the survey and field visit.

We are also thankful to all the technical staff and office staff for helping during the field visit and measurements at the college campus.

EXECUTIVE SUMMARY

After the Field measurements & analysis, we present herewith important observations made and various measures to reduce the Energy Consumption & mitigate the CO₂ emissions

1. Bharati Vidyapeeth's College of Fine Arts, Dhankawadi, Pune, consumes electrical Energy in majority used for various gadgets & office operations.

2. The various projects already implemented by the College are

- Installed APFC of 100kVAR at Main electrical distribution to maintain Power factor.
- Usage of natural day lights and natural air circulation
- Usage of Natural Day light in corridors specifically
- Usage of LED lighting for Admin & outdoor lighting
- Fire extinguishers are installed and maintained for fire safety in the college campus.

3. Important Parameters: Electrical Energy:

Electricity is used for different purposes and at different sections in the college campus. The details of electricity distribution as mentioned below.

Sr. No.	Consumer No.	Electrical Meter No.	Location/Purpose	Payee
1	170019005146	055-XD448280	College building/building operation	Principal, Bharati Vidyapeeth

The important parameters of electrical consumption as per Consumer no. in the campus are mentioned as below.

Sr. No	Consumer No.	Parameter	Max	Min	Average
1	170019005146	Units consumed, kVAh	16232	4031	7436.2
		Electricity Bill amount	370923	197052	246967.7
		Total average units consumed per month, kVAh			7436.2

4. Important Parameters: CO₂ Emissions (Average, MT/Annum)

S. No.	Consumer No.	Particulars	Value MT
1	170019005146	CO ₂ - Emissions- Electricity Usage	71.39
		Total	71.39

On the basis of average electricity consumption CO₂ emission is 71.39MT /annum. In addition to this LPG is being consumed for canteen for food preparation. Nearly LPG consumption annually is 12 commercial cylinders i.e. 228 kg/annum. On the basis of average LPG usage CO₂ emission is 0.68MT/annum.

5. Benchmark: In terms of Electrical Energy & CO₂ emissions:

We now present two important benchmarks in respect of Electrical Energy consumption & CO₂ emissions as under.

No	Particulars	Value	Unit
1	Electrical Energy consumed	0.61	kWh/sq. ft.
3	CO ₂ - Emissions	1.55	Kg per annum /sq. ft.

6. Recommendations:

We present herewith various proposals to reduce the Electrical Energy demand and reduce the CO₂ emissions

S. No.	Recommendation	Annual saving potential in kWh /Kg of LPG	Annual Saving Potential in MT of CO ₂	Annual monetary gain, Rs.
1	Installation of 50kW Solar PV roof top on college building	84000 kWh	67.2	840000
2	Solar street lights	262.8 kWh	0.21	2628
3	Solar powered light for hoarding	-	-	-
4	Solar charging stations	-	-	-
	Total	84262.8	67.41	842628

Notes & assumptions:

- 1 Unit of Electrical Energy releases 0.8 Kg of CO₂ into atmosphere
- 1 Kg of LPG releases 3 Kg of CO₂ into atmosphere
- Daily working hours-10
- Annual working Days-280
- Average Rate of Electrical Energy- Rs 10 per kWh

ABBREVIATIONS

DP	: Double Pole
CFL	: Compact Fluorescent Lamp
EESL	: Energy Efficiency Services Limited
F P	: Feeder Pillar
MSEDCL	: Maharashtra State Electricity Distribution Company Ltd.
MEDA	: Maharashtra Energy Development Agency
MIDC	: Maharashtra Industrial Development Corporation
V	: Voltage
I	: Current
kW	: kilo-Watt
kVA	: Apparent Power
kVA _r	: Reactive Power
P F	: Power Factor
kW _p	: Kilo Watt peak

CHAPTER-I

ENVIRONMENT AND GREEN AUDIT: INTRODUCTION

1.1 Objectives:

1. To Study tree plantation in college campus
2. To Study the present CO₂ emissions
3. To study Scope for usage of Renewable Energy
4. To study various measures for sustainable development

1.2 General Details of Bharati Vidyapeeth's College of Fine Arts, Pune:

No	Head	Particulars
1	Name of Institution	Bharati Vidyapeeth's College of Fine Arts, Pune
2	Address	Pune-Satara Road, Dhankawadi, Pune
3	Year of Establishment	2000
4	Salient Features	Affiliated to Savitribai Phule Pune University
4	Courses offered	BFA Painting and BFA Applied Art
5	No of Students	266
6	Total built up area	45940 Sq. ft.

CHAPTER-II

GREEN AUDIT FOR AY-2023-24

Bharati Vidyapeeth's College of Fine Arts, Pune is one of the leading higher technical educational Institutions of Pune under Savitribai Phule Pune University, Pune. It has been providing quality education in fine arts and technical education to the students in various professional courses. The College is having beautiful green campus and a highly greenery maintenance college in Pune. We have prepared a green audit report after visiting the college campus by our team. This green audit report is based on the following major points.

1. Plantation in the campus
2. Carbon accounting
3. Illumination in class rooms
4. Water audit and Rainwater Harvesting
5. Waste disposal

1. Plantation in the campus

Plantation is playing very important role in the green audit and helping to save environment from damage. The campus plantation is very diverse and well maintained.

The different species are cultivated to increase greenery of the campus. The species included Trees, Shrubs, Herbs, Climbers, ornamentals etc.

There are 33 trees present inside Bharati Vidyapeeth's College of Fine Arts, Pune campus. After a daylong survey and records about the plantation in the campus is prepared which is as per following table.

Sr. No.	Name of the Plant	Count
1	Sada Chapha (Plumeria)	08
2	Mohogani (Swietenia macrophylla)	05
3	Kejurina (Casuarina equisetifolia)	01
4	Kashid (Senna siamea)	04
5	Gorakh Chinch (Adansonia digitata)	02
6	Bakul (Mimusops elengi)	04
7	Phulmeria	06
8	Sptapadi (Alstonia scholaris)	01
9	Badam (Almond)	01
10	Chapha (Plumeria)	01
	Total	33

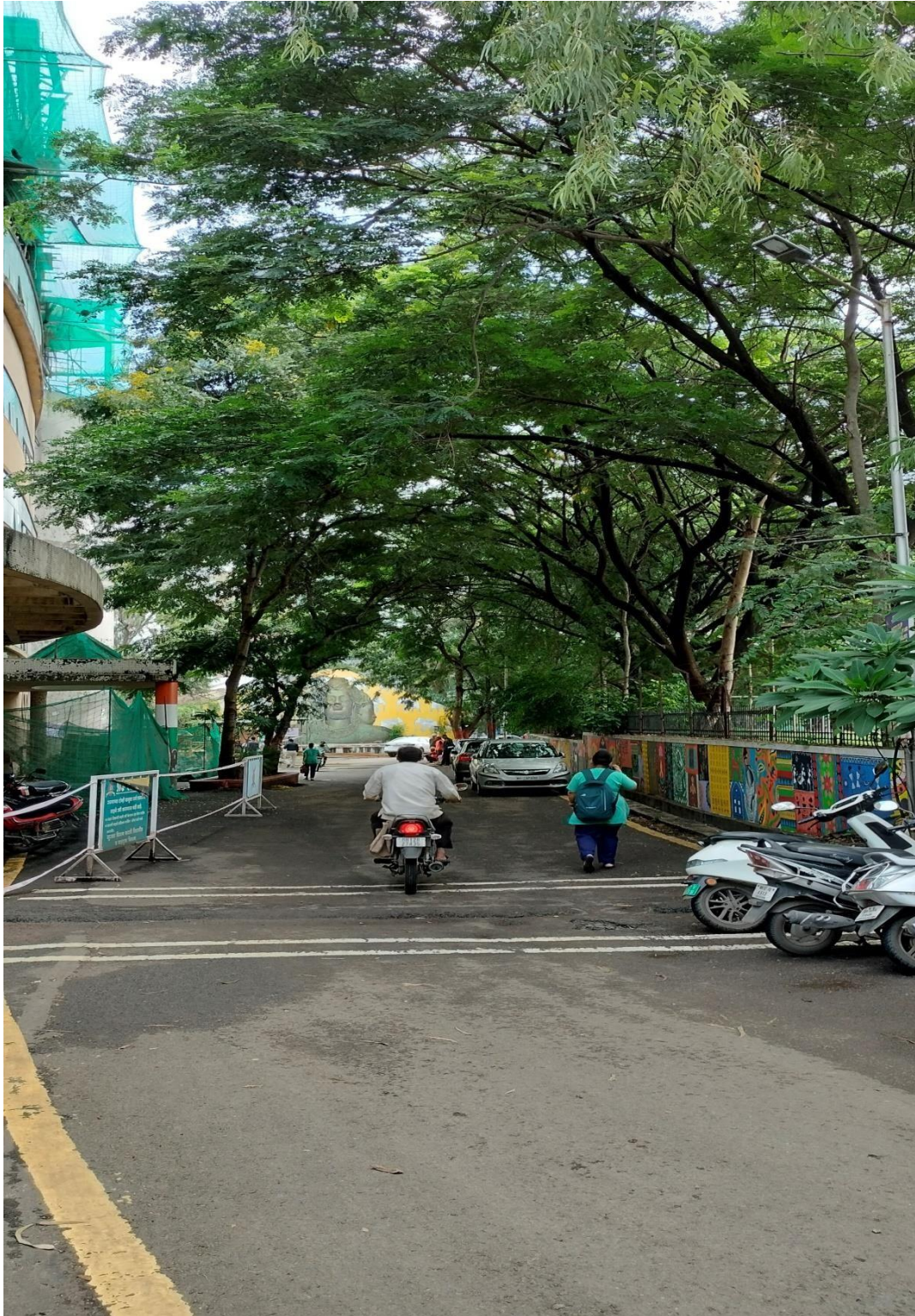

Photo-1: Entry view with tree plantation of Bharati Vidyapeeth's College of Fine Arts, Pune



Photo-2: Tree Plantation at Bharati Vidyapeeth's College of Fine Arts, Pune



Photo-3: Lawn at Bharati Vidyapeeth's College of Fine Arts, Pune

1.1 Calculation of amount of CO_2 sequestered in trees per year

The carbon sequestration potential of the plant species present in green belt has been estimated and suitable plant with maximum sequestration of CO_2 was recommended. Carbon sequestration is nothing but capturing atmospheric carbon dioxide or anthropogenic CO_2 from large scale stationary sources like cement industry before it is released to the atmosphere. Once captured, the CO_2 gas is put into long term storage. CO_2 sequestration in plants has the potential to significantly reduce the level of carbon that occurs in the atmosphere. Terrestrial or biologic sequestration means using plants to capture CO_2 from the atmosphere and then storing it as carbon in the stems and roots of

the plants as well as in the soil. The green belts in industrial area acts as sink for capturing and storing carbon dioxide released from the industries.

Assessment of carbon sequestration ability of trees for adopting in greenbelt of cement industries

The carbon dioxide sequestered in plant species are determined based on following method:

1. Determine the total (green) weight of the tree
2. Determine the dry weight of the tree
3. Determine the weight of carbon in the tree
4. Determine the weight of carbon dioxide sequestered in the tree
5. Determine the weight of CO₂ sequestered in the tree per year

1.2 Determination of Total (Green) Weight of the Tree

The algorithm to calculate the weight of a tree is:

For trees with $D < 11$: $W = 0.25D^2H$

For trees with $D \geq 11$: $W = 0.15D^2H$

Where, W = Above-ground weight of the tree in pounds

D = Diameter of the trunk in inches

H = Height of the tree in feet

Depending on the species, the coefficient (e.g. 0.25) could change and the variables D^2 and H could be raised to exponents just above or below 1. However, these two equations could be seen as an "average" of all the species' equations. The root system weighs about 20% as much as the above-ground weight of the tree. Therefore, to determine the total green weight of the tree, multiply the above-ground weight of the tree by 120%.

1.3 Determination of Dry Weight of the Tree

Taking all species in into account, the average tree is 72.5% dry matter and 27.5% moisture.

Therefore, to determine the dry weight of the tree, multiply the weight of the tree by 72.5%.

1.4 Determine the weight of carbon in the tree

The average carbon content is generally 50% of the tree's total volume. Therefore, to determine the weight of carbon in the tree, multiply the dry weight of the tree by 50%.

Assessment of carbon sequestration ability of trees for adopting in greenbelt of cement industries

Determine the weight of carbon dioxide sequestered in the tree

CO₂ is composed of one molecule of Carbon and 2 molecules of Oxygen.

The atomic weight of Carbon is 12.001115.

The atomic weight of Oxygen is 15.9994.

The weight of CO₂ is $C+2*O=43.999915$.

The ratio of CO₂ to C is $43.999915/12.001115=3.6663$.

Therefore, to determine the weight of carbon dioxide sequestered in the tree, multiply the weight of carbon in the tree by 3.6663

Determine the weight of CO₂ sequestered in the tree per year

Divided the weight of carbon dioxide sequestered in the tree by the age of the tree.

2. Carbon Accounting

A **Carbon Foot print** is defined as the Total Greenhouse Gas emissions, emitted due to various activities.

In this we compute the emissions of Carbon-Di-Oxide, by usage of the various forms of Energy used by the College for performing its day to day activities. The college uses electrical energy for operating various electrical gadgets.

We herewith furnish the details of electrical Energy consumption consumer number wise as under

2.1 Month wise Consumption of Electrical Energy: 170019005146

Sr. No	Month	kVAh
1	July-23	16232
2	June-23	6303
3	May-23	4663
4	April-23	6290
5	March-23	4583
6	Feb-23	4351
7	Jan-23	6573
8	Dec-22	7286
9	Nov-22	4397
10	Oct-22	4031
11	Sep-22	14731
12	Aug-22	9795
13	Total	89235
14	Average	7436.2
15	Max	16232
16	Min	4031

2.2 Basis for computation of CO₂ Emissions:

The basis of Calculation for CO₂ emissions due to Electrical Energy are as under

- 1 Unit (kWh) of Electrical Energy releases **0.8 Kg of CO₂** into atmosphere

Based on the above Data we compute the CO₂ emissions which are being released in to the atmosphere by the College due to its Day to Day operations.

2.3 Month wise CO2 Emissions: 170019005146

Sr. No	Month	Electrical Energy Consumed, kVAh	CO2 Emissions due to Electricity, MT
1	July-23	16232	12.99
2	June-23	6303	5.04
3	May-23	4663	3.73
4	April-23	6290	5.03
5	March-23	4583	3.67
6	Feb-23	4351	3.48
7	Jan-23	6573	5.26
8	Dec-22	7286	5.83
9	Nov-22	4397	3.52
10	Oct-22	4031	3.22
11	Sep-22	14731	11.78
12	Aug-22	9795	7.84
13	Total	89235	71.39
14	Average	7436.2	5.95
15	Max	16232	12.99
16	Min	4031	3.22

2.4 Representation of Month wise CO₂ emissions:

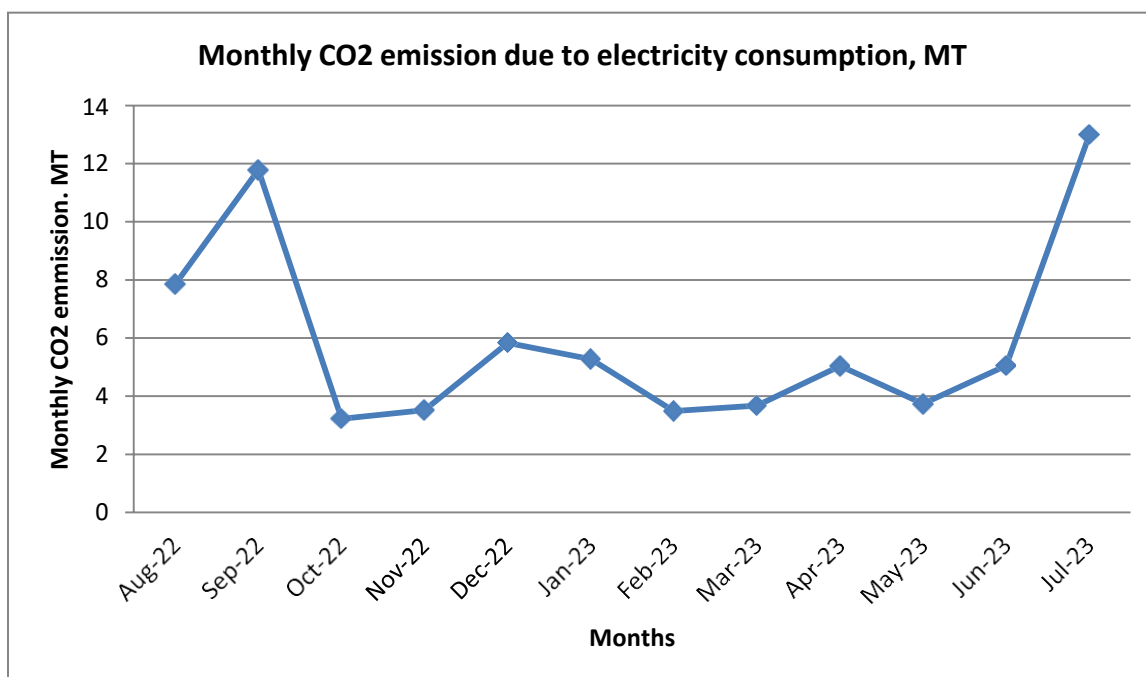

2.5 Benchmarking:

Now we compute the CO₂ emissions per sq. ft. basis as under:

S.No.	Parameter	Value	Unit
1	CO ₂ emissions	71.39	MT/annum
2	College area	45940	Sq. ft.
3	CO ₂ emissions/sq. ft.	1.55	Kg of CO ₂ per annum/sq. ft.

3. Use of Renewable energy options for saving the environment

3.1 Installation of 50 kWp Solar PV roof Top on Bharati Vidyapeeth's College of Fine Arts building:

During the Audit, it was revealed that the College has ample space on the Terrace but top two floors under construction. It is proposed once construction completes Solar Photovoltaic roof top with net meter of capacity **50 kWp can be installed**. The system will cater the Day load Demand of the College.

We furnish herewith the saving potential as under

No	Particulars	Value	Unit
1	Installed Capacity of Solar PV Pack	50	kWp
2	Daily working period	6	Hrs./Day
3	Daily units generated	300	kWh/Day
4	Annual working days	280	Day/annum
5	Annual saving in Grid Electrical Energy	84000	kWh/annum
6	Annual CO ₂ saving potential	67.2	MT/Annum
7	Present Energy Charges	10	Rs/kWh
8	Annual monetary Gain	840000	Rs/Annum
9	Investment required	22,50000	Rs lump sum
10	Payback period	2.67	Years

3.2 Solar powered light for hoarding

Lighting solar systems are the fixed installations designed for domestic as well as small scale commercial application. The component of the solar lighting system includes solar PV module (solar cells), charge controller, solar battery and lighting system (lamps & fans). Modules are installed in the open on roof/terrace - exposed to sunlight and the charge controller and battery are kept inside a protected place in the house.



Figure-1: Solar powered light for Hoarding

This system comes with multiple benefits such as:

- **Economical:** Since the sun provides energy free of charge, 30% power savings on the electricity bill can be availed with longer back up lighting system at zero running cost.
- **Non-Polluting:** Powered by the sun's renewable energy, the system is energy neutral and an absolutely clean source of illumination. 1kWp solar installation reduces 1/2 ton of CO₂ (carbon dioxide) per annum.
- **No Maintenance:** The system has few moveable parts - reducing the risk of breakage. Once installed, it lasts for long time and requires little attention.

This system can be used to power the huge hoardings in the college campus.

Solar powered hoarding lighting system proposed will provide a better, faster, cheaper (and cleaner) alternative with solar. Since this product competes with diesel or conventional fuels, we needed to ensure we beat the cost of a diesel solution. In order to achieve that with solar, we consider the following system:

1. Highly Efficient Solar Panel
2. Charge Controllers with MPPT Technology - increases solar electricity production by up to 30% compared to conventional charge controllers
3. LED Projection Light - consumes 10-times less electricity compared to conventional bulbs, and has a 50,000 hour warranty.

Features:

- Auto on off

- 4 Days Battery Back Up
- Robust housing
- Weather proof

With this entire put together, we ended up with systems that provide 6 hours of lighting each night with 4 -lamp system to light up boards up to 15'x30', and a 8-lamp system to light larger boards up to 20'x40'. More importantly, with these options, payback of the system will come around 2.5 years. This system provides a way to reduce the lightings costs, get rid of all the operational hassles of owning a diesel generator, plus brand benefits from being "green" with the use of renewable energy like solar powered light hoarding board.

3.3 Solar charging stations

Solar cell phone chargers use solar panels to charge cell phone batteries. They are an alternative to conventional electrical cell phone chargers and in some cases can be plugged into an electrical outlet. Solar mobile charger is a device which can charge mobile phones using solar radiation. Its major component is a compact solar panel. This solar panel traps solar energy and produces an output voltage. But, since the light radiations falling on the solar panel can vary, the output voltage becomes unstable. For charging a mobile phone, stable voltage is required. So, to make the output voltage stable and regulated, voltage regulator circuit along with the solar panel is used.

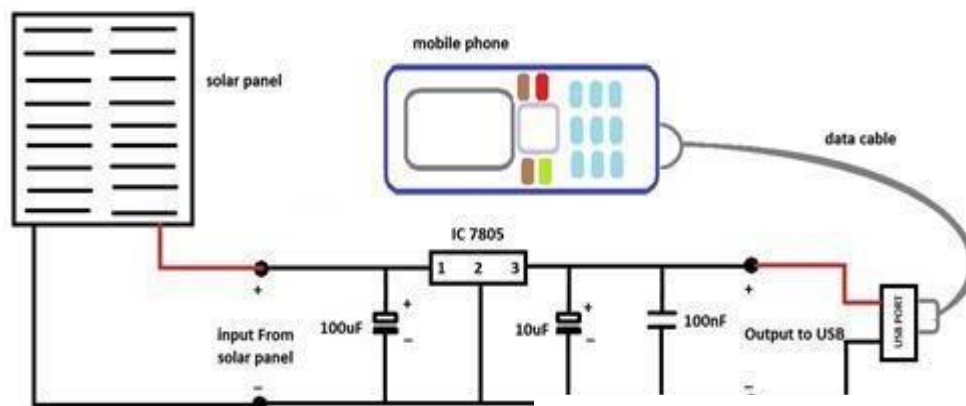

Figure-2: Solar charging Stations

Most of the mobile phones have computer connectivity via USB cable. USB port establishes 4 connection terminals. The connection terminals at the two extreme ends are the supply terminals. In a female USB connector (port via which we plug in USB devices to computer), these terminals carry 5V DC. When a mobile phone is connected to the USB port of a computer, it utilizes this 5V supply to recharge battery. This feature is used in a solar mobile charger. It converts and regulates solar energy to 5V DC and the output will be available through the female USB connector. To this connector, we can easily connect a mobile phone via data cable.

4. Illumination in class rooms

Lighting puts a huge impact on the visibility and appearance of every space. Sufficient and beautiful lighting can enhance the look of a dull space, whereas improper lighting implementations can make a catchy area look less impressive. Poor lighting at work can lead to eye-strain, fatigue, headaches, stress and accidents. On the other hand, too much light can also cause safety and health problems such as “glare” headaches and stress. Bharati Vidyapeeth's College of Fine Arts is using daylight effectively, specifically at corridors. The typical class room illumination in lux is mentioned as below.

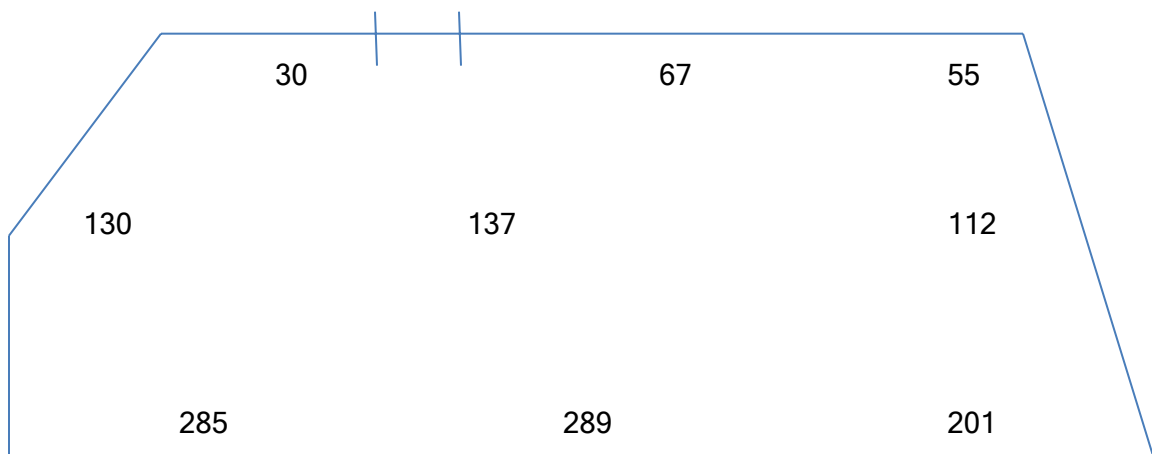

Figure 3: Applied Arts Forth Year (Ground Floor)

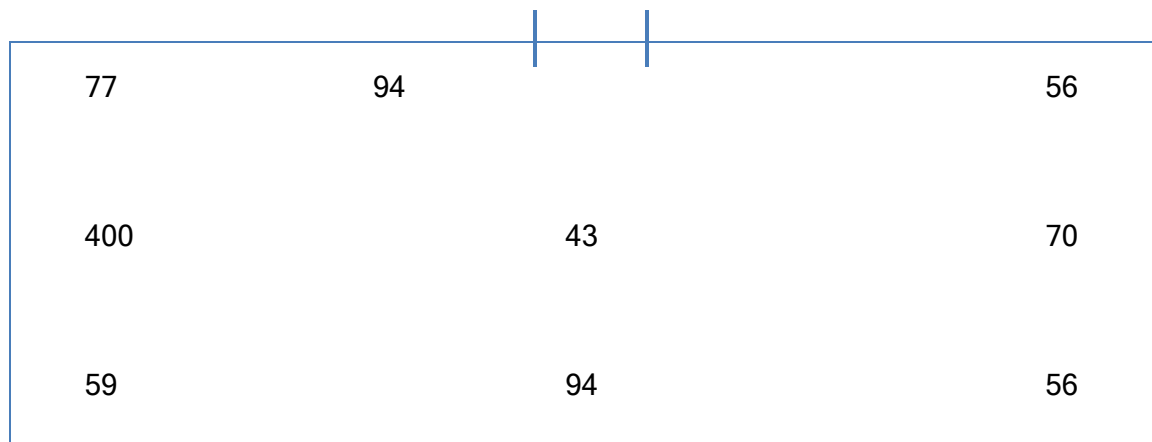

Figure 4: Library (First Floor)

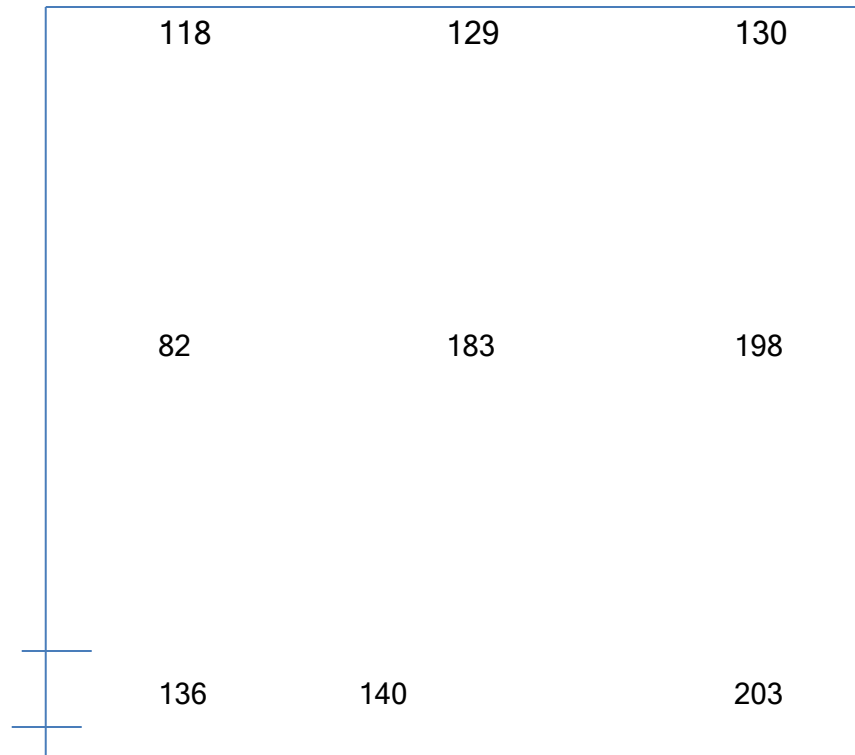

Figure 5: Foundation class (Fourth Floor)

5. Water Audit and Rain water harvesting

A water crisis is a very sensitive issue these days all over the world. Recently we are facing water crisis in major part of Maharashtra like Marathwada, Khandesh, Pachim Maharashtra and North Maharashtra. Bharati Vidyapeeth's College of Fine Arts, Pune has taken a good initiative for maintaining greenery in the campus and less concrete zone, it means that college campus is allowing the rainwater to absorb under the ground and maintain the underground water level. In addition to this as per the survey and site location following activities can be implemented for the conservation of water.

5.1 Water storage and consumption

Bharati Vidyapeeth's College of Fine Arts campus is having water supply from Pune Municipal Corporation to mitigate the need of requirement water for various activities. The college campus has temporary water storage capacities in terms of overhead tanks on the Institute building. Water is temporarily stored in the campus for various activities. There is a provision of sparkler system to supply the water in garden to maintain greenery. The details of water storage in the campus as mentioned below.

Tank type	For Regular Use (ltr)	Quantity
For regular Use in the building	40000	01

5.2. Rain water harvesting

The system of rain water harvesting is an integral part of any educational institution. This system helps to conserve the rain water and also to use during the time of its desirable. This system helps the students to understand the basic concepts of rainwater harvesting system and their effective use in the real life.

Already Bharati Vidyapeeth's College of Fine Arts have provisions of collection of gray waste water from all the building taken through some specific path and charged in the ground below building to maintain the ground level water. It is suggested to charge the rain water through ring well in the campus.



Photo-4: View of rain water collection from building

Advantages of rain water harvesting

- (a) Promotes adequacy of underground water
- (b) Mitigates the effect of drought
- (c) Reduces soil erosion as surface run-off is reduced
- (d) Decreases load on storm water disposal system
- (e) Reduces flood hazards
- (f) Improves ground water quality / decreases salinity (by dilution)
- (g) Prevents ingress of sea water in subsurface aquifers in coastal areas
- (h) Improves ground water table, thus saving energy (to lift water)
- (i) The cost of recharging subsurface aquifer is lower than surface reservoirs
- (j) The subsurface aquifer also serves as storage and distribution system
- (k) No land is wasted for storage purpose and no population displacement is involved
- (l) Storing water underground is environment friendly.

Rain water harvesting potential

The total amount of water that is received in the form of rainfall over an area is called the rain water endowment of that area. Out of this, the amount that can be effectively harvested is called rain water harvesting potential.

All the water which is falling over an area cannot be effectively harvested, due to various losses on account of evaporation, spillage etc. Because of these factors the quantity of rain water which can effectively be harvested is always less than the rain water endowment. The collection efficiency is mainly dependent on factors like runoff coefficient and first flush wastage etc. Runoff is the term applied to the water that flows away from catchments after falling on its surface in the form of rain.

Runoff depends upon the area and type of catchment over which it falls as well as surface features. Runoff can be generated from both paved and unpaved catchment areas. Paved surfaces have a greater capacity of retaining water on the surface and runoff from unpaved surface is less in comparison to paved surface. In all calculations for runoff estimation, runoff coefficient is used to account for losses due to spillage, leakage, infiltrations catchment surface wetting and evaporation, which will ultimately result into reduced runoff. Runoff coefficient for any catchment is the ratio of the volume of water that run off a surface to the total volume of rainfall on the surface. The runoff coefficient for various surfaces is given in following table

Sr. No.	Type of catchment	Coefficient
1	Roof Catchments	
	Tiles	0.8-0.9
	Corrugated metal sheets	0.7-0.9
2	Ground surface coverings	
	Concrete	0.6-0.8
	Brick pavement	0.5-0.6
3	Untreated ground catchments	
	Soil on slopes less than 10%	0.0-0.3
	Rocky natural catchments	0.2-0.5

Based on the above factors, the water harvesting potential of site could be estimated using the following equation:

Rain Water harvesting potential = Amount of Rainfall x area of catchment x Runoff coefficient

Rain water harvesting methods

- (a) Storing rain water for direct use
- (b) Recharging ground water aquifers, from roof top run off
- (c) Recharging ground water aquifers with runoff from ground area

According to the site of Bharati Vidyapeeth's College of Fine Arts campus the method of recharging ground water aquifers from roof top run off may be suitable.

Recharging ground water aquifers from roof top run off

Rain water that is collected on the roof top of the building may be diverted by drain pipes to a filtration tank (for bore well, through settlement tank) from which it flows into the recharge well, as shown in following Figure. The recharge well should preferably be shallower than the water table. This method of rain water harvesting is preferable in the areas where the rainfall occurs only for a short period in a year and water table is at a shallow depth. The schematic diagram of recharging water aquifers from roof top run off is as follows.

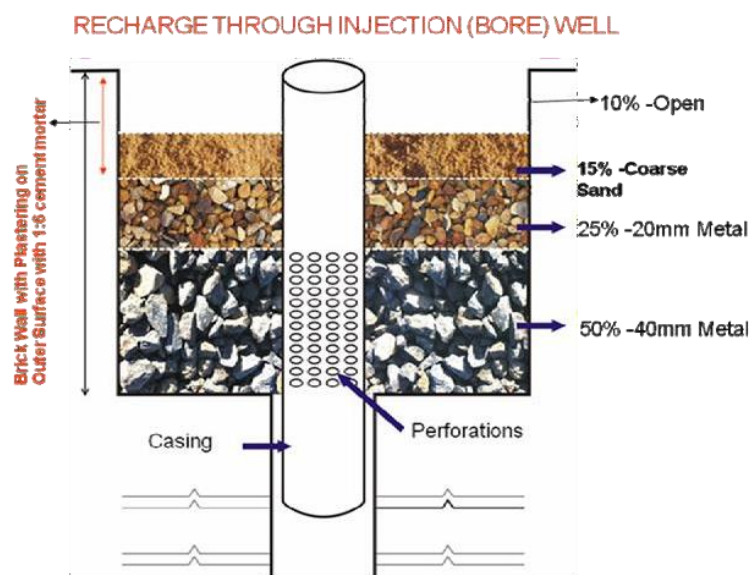

6. Waste disposal

The present Prime Minister of India, Shri Narendra Modiji launched “ Swach Bharat Abhiyan” (Clean India Mission), on 2nd October, 2014. In this mission, the proper use of dustbins is one of the major priorities. For the successful implementation of this mission collective mass effort is necessary. The higher education institutions like Bharati Vidyapeeth's College of Fine Arts, Pune need to play a major role in this regard to keep their campus neat and clean. Proper use of dustbins is not only the solution for the generating garbage in the college campus. Now days, its proper treatment should be given a major priority.

Characteristic and Disposal Practices of Solid Wastes Waste Management

Sr. No.	Waste Category	Method of disposal
1	Solid waste from trees droppings and lawn	Vermi Composting Organic Manure
2	Canteen waste	Vermi Composting Organic Manure
3	Plastic waste	Through Authorized recycler after segregation
4	Solid Waste from Lab	Solid Waste from Lab
5	Chemical waste generated in chemistry	The college is need to have a very good practice to use dilute chemicals for the experimentation in these labs. These dilute chemicals can be further diluted and disposed in the pit near the lab.
6	E-waste and defective items from computer and electronics lab	The institution collect e-waste and delivered to authorized agency in order to dispose E-waste in scientific manner.
7	Sanitary Napkins	The institution have to take a very good initiative to install sanitary napkin disposal machine at the different location in the college campus. It is suggested to install vending machine along with incinerators at required locations in the college campus.

6.1 Vermiculture Composting Culture

Vermicomposting is basically a managed process of worms digesting organic matter to transform the material into a beneficial soil amendment. The main purpose of this is to reduce disposable waste in the college campus and after complete process of vermi composting it is used as manure for plantation and greenery in the campus. It is also used for the demonstration and awareness in farmers to implement organic farming and its importance.

The main benefits of the process are to reduce the waste in the environment and utilized for some useful purpose and also it is cost savings process.

The earthworms being voracious eaters consume the biodegradable matter and give out a part of the matter as excreta or vermi-castings. The vermi-casting containing nutrients is a rich

manure for the plants. Vermicompost, apart from supplying nutrients and growth enhancing hormones to plants, improves the soil structure leading to increase in water and nutrient holding capacities of soil. Fruits, flowers and vegetables and other plant products grown using vermicompost are reported to have better keeping quality. A growing number of individuals and institutions are taking interest in the production of vermicompost utilizing earthworm activity. As the operational cost of production of this compost works out to less than ` Rs. 2.0/Kg., it is quite profitable to sell the compost even at Rs. 4.00 to 4.50/Kg.

Process:

The process of composting crop residues / agri wastes using earthworms comprise spreading the agricultural wastes and cow dung in gradually built up shallow layers. The pits are kept shallow to avoid heat built-up that could kill earthworms. To enable earthworms to transform the material relatively faster a temperature of around 30°C is maintained. The final product generated by this process is called vermicompost which essentially consist of the casts made by earthworms eating the raw organic materials. The process consists of constructing brick lined beds generally of 0.9 to 1.5 m width and 0.25 to 0.3 m height are constructed inside a shed open from all sides. For commercial production, the beds can be prepared with 15 m length, 1.5 m width and 0.6 m height spread equally below and above the ground. While the length of the beds can be made as per convenience, the width and height cannot be increased as an increased width affects the ease of operation and an increased height on conversion rate due to heat built up.

Cow dung and farm waste can be placed in layers to make a heap of about 0.6 to 0.9 m height. Earthworms are introduced in between the layers @ 350 worms per m³ of bed volume that weighs nearly 1 Kg. The beds are maintained at about 40-50% moisture content and a temperature of 20-30° C by sprinkling water over the beds. When the commercial scale production is aimed at, in addition to the cost of production, considerable amount has to be invested initially on capital items. The capital cost may work out to about Rs. 5000 to 6000 for every tonne of vermicompost production capacity. The high unit capital cost is due to the fact that large units require considerable expenditure on preparation of vermi beds, shed to provide shelter to these beds and machinery. However these expenditures are incurred only once.

Under the operational cost, transportation of raw materials as also the finished product are the key activities. When the source organic wastes and dung are away from the production facility and the finished product requires transportation to far off places before being marketed, the operational cost would increase. However, in most of the cases, the activity is viable and bankable. Following are the items required to be considered while setting up a unit for production of vermi-compost.

Components of a Commercial Unit

Commercial units have to be developed based on availability of cow dung locally. If some big dairy is functioning then such unit will be an associated activity. Commercial units must not be designed based on imported cow dung.

1. Sheds

For a vermi-composting unit, whether small or big, this is an essential item and is required for securing the vermi beds. They could be of attached roof supported by bamboo rafters or steel trusses. Locally available roofing materials or HDPE sheet may also be used in roofing to keep the capital investment at reasonably lower level. If the size is so chosen as to prevent wetting of

beds due to rain on a windy day, they could be open sheds. While designing the sheds adequate room/pathways has to be left around the beds for easy movement of the labourers attending to the filling and harvesting the beds.

2. Vermi-beds

Normally the beds have 0.3 to 0.6 m height depending on the provision for drainage of excess water. Care should be taken to make the bed with uniform height over the entire width to avoid low production owing to low bed volumes. The bed width should not be more than 1.5 m to allow easy access to the center of the bed.

3. Fencing and Roads/Paths

The site area needs development for construction of structures and development of roads and pathways for easy movement of hand-drawn trolleys/wheel barrows for conveying the raw material and the finished products to and from the vermi-sheds. The entire area has to be fenced to prevent trespass by animals and other unwanted elements. These could be estimated based on the length of the periphery of the farm and the length and type of roads/paths required. The costs on fencing and formation of roads should be kept low as these investments are essential for a production unit, yet would not lead to increase in production.

4. Water Supply System

As the beds have to be kept moist always with about 50% moisture content, there is a need to plan for a water source, lifting mechanism and a system of conveying and applying the water to the vermi-beds. Drippers with round the clock flow arrangement would be quite handy for continuous supply and saving on water. Such a water supply system requires considerable initial investment. However, it reduces the operational cost on hand watering and proves economical in the long run. The cost of these items would depend on the capacity of the unit and the type of water supply chosen.

5. Transportation

For any vermi-composting unit transport arrangement is a must. When the source of raw material is away from the production unit, an off-site transport becomes major item of investment. A large sized unit with about 1000 tonnes per annum capacity may require a three tonne capacity mini-truck. With small units particularly with the availability of raw material near the site, expending on transport facility may become infructuous. On-site transport facilities like manually drawn trolleys to convey raw material and finished products between the storage point and the vermi-compost sheds could also be included in the project cost.

Design calculations

The size of the bed can be selected as per the space available and convenient to the customer. Brick lined beds generally of 0.9 to 1.5 m width and 0.25 to 0.3 m height are constructed inside a shed open from all sides. On the basis of site survey and suitability of operation let's consider following dimensions for the bed. Generally, earthworms are introduced in between the layers @ 350 worms per m³ of bed volume that weighs nearly 1 Kg.

$$L = 3 \text{ m}$$

$$W = 1.5 \text{ m}$$

$$H = 0.6 \text{ m}$$

$$\text{Volume of the bed} = 2.7 \text{ m}^3$$

$$\text{Input} = \frac{15 \text{ kg of organic residue}}{m^3 \times 15 \text{ days}} = \frac{1 \text{ kg of organic residue}}{m^3 \times 1 \text{ day}}$$

It means for 2.7 m³, 270 kg of organic residue is required. Therefore for a month approximately 8100 kg (8.1 Ton) of organic residue is required.

The financial viability on the basis of available data of the vermicompost system is shown below.

Sr. No.	Particulars	Expenditure Cost (Rs.)
1	Bed construction	Already available 10,000/-
2	Fencing including roof	5000/-
3	Water Dripper	3000/-
4	Electrical connections	1000/-
5	Earthworms	1000/-
6	Salary & wages	20000/-
7	Sale of Vermicompost (@ Rs.100 /kg at 30% conversion)	121500/-
	Net Benefit	81500/-



Photo-5: Beds for Vermi-compost at college campus

Chapter III

SUGGESTIONS AND RECOMMENDATIONS

Following are the suggestions and actions on the basis of green and environmental audit are suggested to implement in the campus on the basis of funds availability and institute preferences.

Green Audit: Environment conservation opportunities:

- Plants/Trees in the college campus may be designated with botanical name and specific number on the basis of year of plantation. There will be brick arrangement at the bottom to supply water to the plant.
- Water management system must be in place. Reduction in water consumption by addressing leakages of taps and other miscellaneous utilities. Installation of flow meters which will help in reduction of water consumption. TOD can be implemented for water pumping application.
- Rainwater harvesting pipe which collects rain water from respective building may have filter and properly charge the ground through ring well.
- Provide required nos. of dustbins at respective locations in the college campus.
- Vermi-culture composting plant should be in working condition and the organic compost from the same will be either utilized for the plants/trees and maintaining greenery in the college campus or sell for organic farming.
- It is suggested to display Energy conservation slogans boards in the college campus and classroom to make awareness about importance of energy saving.